

**EYELA**

Essential Equipment for  
Advanced Laboratory Use.



# Rotary Evaporator

TOKYO RIKAKIKAI CO., LTD.

## N-1001 series Rotary Evaporator

### Quality design with broad versatility

- Economic and durable Rotary Evaporator with a flexible modular design. Accommodates an integrated vacuum controller, solvent recovery system, and vacuum pump. Easily adapted to meet more demanding needs.
- Three glassware configurations: Diagonal (S), used for standard applications; Vertical (V), used in space-constrained and elevated boiling point applications; Dewar (T) configuration, designed for low boiling point applications.
- Two water bath options: the SB-1000 is designed for standard applications and accommodates up to a 3L volume, with a 50ml to 1000ml evaporating flask range. The OSB-2000 is used in applications requiring temperatures up to 180°C and 7L maximum bath volume capacity, allowing for usage of evaporating flasks as small as 50ml and as large as 2000ml.
- Unique counterbalanced sliding jack with newly integrated lock system allows easy single-hand management of the evaporating flask height.
- The N-1001 series can elevate up to 10 ¼" (260mm), allowing for safe and effortless evaporating flask attachment and detachment.
- The quiet motor head operates between 20 and 180 rpm.
- The wide surface area (0.11m<sup>2</sup>) of the condenser provides excellent cooling while effectively recovering solvent.
- The water bath features an integrated overheat protector and thermal fuse with PTFE coating, providing greater durability and protection against corrosion.
- Chemical resistant Teflon seals (optional) allow for the recovery of low boiling point organic solvents.



N-1001S-W

### Smooth Operating Variable Height Jack



Easy-to-use  
Control Panel



Convenient Digital  
Bath Thermostat

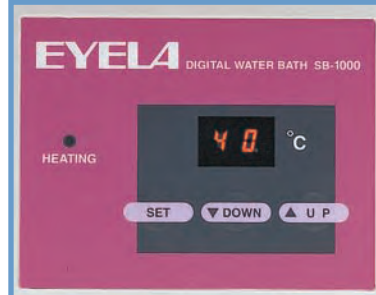

N-1001T-W  
Dewar Model



N-1001V-W  
Vertical Model



No Exposed  
Heating Element



Manual Extension Slide  
for trap bulb



Spring Loaded  
Locking Jack Handle



Reverse Flow  
Prevention Adapter  
(N1001V and T)



## Evaporating Capability

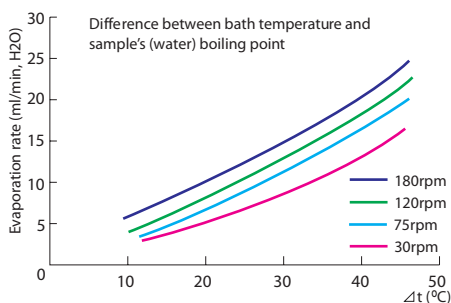

Condition: Temperature of cooling water is 10°C ~ 20°C lower than boiling point of sample (water).  
Room temperature: 25 ~ 27°C Evaporating Flask 1L (Feed amount: 500mL)

## Protective Safety Shield



In case of broken glass, the protective shield prevents harmful glass fragments from scattering. (SB1000 only) Cat. No. 195070

## Electric Teflon Valve (optional)



Product Name	Rotary Evaporator			
Model	N-1001S	N-1001S-W	N-1001S-WD	
Cat. No.	214429	216949	216959	
Type	W/O Water Bath	With Water Bath	With Large Size Water / Oil Bath	
Condenser	Standard Diagonal Condenser Glassware, Nozzle OD 3/8" (10mm) Cooling Surface 0.11m <sup>2</sup>			
Evaporating Flask	Pear Shaped Flask 1 Liter NS 24/40			
Receiving Flask	Round Bottom Receiving Flask 1 Liter Ball Joint Size 35/20			
Rotary Joint (Vapor Duct)	ID 3/4" (18mm) x 10 3/4" (272mm) NS24/40			
Vacuum seal	Teflon + Teflon/Viton Double Seal			
Overall Dimensions	inc.	26"W x 12 5/8"D x 20"H 30"H Max	28"W x 14"D x 20"H 30"H Max	28 3/4"W x 15"D x 20"H 30"H Max
	mm	660W x 320D x 510H 760H Max	710W x 355D x 510H 760H Max	730W x 380D x 510H 760H Max
Net Weight	17.6lb (8kg)	24.2lb (11kg)	27.5lb (12.5kg)	
Model	N-1001V	N-1001V-W	N-1001V-WD	
Cat. No.	216969	216979	216989	
Condenser	Vertical Condenser Glassware, Nozzle OD 3/8" (10mm) Cooling Surface 0.11m <sup>2</sup>			
Evaporating Flask	Pear Shaped Flask 1 Liter NS 24/40			
Receiving Flask	Round Bottom Receiving Flask 1 Liter Ball Joint Size 35/20			
Rotary Joint (Vapor Duct)	ID 3/4" (18mm) x 7" (178mm) NS24/40			
Vacuum Seal	Teflon + Teflon/Viton Double Seal			
Overall Dimensions	inc.	19"W x 12 5/8"D x 35 2/5"H 45 2/7" H Max	21 1/8"W x 14"D x 35 2/5"H 45 2/7" H Max	21 3/5"W x 14"D x 35 2/5"H 45 2/7" H Max
	mm	480W x 320D x 900H 1150H Max	535W x 355D x 900H 1150H Max	550W x 355D x 900H 1150H Max
Net Weight	18.7lb (8.5kg)	25.3lb (11.5kg)	28.6lb (13kg)	
Model	N-1001T	N-1001T-W	N-1001T-WD	
Cat. No.	216999	217009	217019	
Condenser	Dewar Condenser Glassware, Nozzle OD 3/8" (10mm) OD 4 3/8" x 13 3/8" (110 x 340mm) ID 3 5/8" x 9 1/8" (91 x 230mm)			
Evaporating Flask	Pear Shaped Flask 1 Liter NS 24/40			
Receiving Flask	Round Bottom Receiving Flask 1 Liter Ball Joint Size 35/20			
Rotary Joint (Vapor Duct)	ID 3/4" (18mm) X 7" (178mm) NS24/40			
Overall Dimensions	inc.	19"W x 12 5/8"D x 28 3/4"H 38 3/5" H Max	21 1/8"W x 14"D x 28 3/4"H 38 3/5" H Max	21 3/5"W x 15"D x 28 3/4"H 38 3/5" H Max
	mm	480W x 320D x 730H 980H Max	535W x 355D x 730H 980H Max	550W x 380D x 730H 980H Max
Net Weight	18.9lb (8.6kg)	25.5lb (11.6kg)	28.8lb (13.1kg)	
Common Specifications				
Rotation Speed	20-180rpm			
Evaporating Capacity	20ml/min Max (Water)			
Ultimate Vacuum	4mbar(399.9Pa) or less			
Safety Features	Fuse	Independent Over Temperature Shut Off		
Jack Function	Manual Slide (Weight Balance Slide + Extension Slide)			
Jack Stroke	4 3/8" (110mm) + 5 7/8" (150mm) (Weight Balance Slide + Extension Slide)			
Stand Base	T Shape Base 15 3/4" (400mm) x 12 5/8" (320mm)			
Motor	Induction Motor 25W			
Bath Temp. Range	----	5°C above ambient to 90°C	5°C above ambient to 180°C	
Accuracy	----	+/-1.5°C	+/-1.5°C (Oil: +/-3.0°C)	
Display	----	Digital Set and Read Out, Min Figure 1°C		
Heater	----	1kW (Drum Heating) for Water	1kW (Drum Heating) for Water and Oil	
Bath Size, Material and Capacity	inc.	----	ID 9 1/8" x 6 3/8" x 4"H, SUS 304, 3 Liters	ID 10" x 5 3/8"H, SUS 304, 7 Liters
	mm	----	ID 230 x 160 x 100H, SUS 304, 3 Liters	ID 253 x 135H, SUS 304, 7 Liters
Additional Power Plug	----	Max 1A		
Ambient Temperature	5 to 35°C			
Supply Power	35VA	1035VA		

## NVC-2100 Vacuum Controller



The NVC-2100 Vacuum Controller enables complete automation of the evaporation process. It comes equipped with an Anti-Corrosion Semiconductor Sensor that automatically regulates the amount of vacuum in the rotary evaporator condenser, improving the recovery rate of hazardous solvents. Implementing an optional Teflon Solenoid vacuum control valve enables the user to variably regulate the amount of vacuum depending on the type of solvent being used.

The LCD screen features vacuum measurement, pressure value, and vapor temperature (optional) settings in an easy-to-read display.

**Select between Normal, Auto, Program, or Step Program modes:**

**Normal Mode:** Allows the user to adjust pressure while simultaneously monitoring concentration during operation as well as shutdown. After selecting the appropriate pressure, the controller starts automatically, eliminating the need to press the start button or adjust other settings.

**Auto Mode:** After setting the desired vapor temperature (optional), the controller will automatically determine the optimal level of vacuum and initiate evaporation while also regulating solvent "bumping."

**Program Mode:** Optimal vacuum settings for 10 different solvents are programmed and stored in memory (diethyl ether, dichloromethane, acetone, dichloroethane, chloroform, trichloroethane, ethyl acetate, benzer, benzene, and toluene).

**Step Program Mode:** Allows user to program up to 20 steps into the evaporation process, including climb, descent gradient, stationary control, and atmospheric pressure release options. A built-in AC outlet for a diaphragm pump allows the user to automatically regulate the pump via controller, including when to start and stop the operation.

A Teflon electromagnetic valve (sold separately) is equipped with a Teflon diaphragm and an anticorrosion sensor (optional) for organic solvent, providing excellent corrosion resistance.

## Graphical Display Function

The Graphical Display Function allows the user to monitor the decompression process, gradient control status, and constant value control.

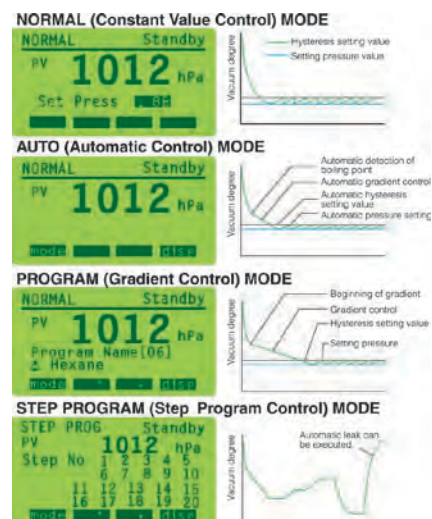

### Recovery rate

Program mode		Concentration time	Recovery amount	Recovery rate	
99.78% of toluene was recovered.	Diethyl ether	8'28"	493.5g	98.70%	
	Dichloromethane	8'22"	487.0g	97.40%	
	Acetone	13'48"	497.0g	99.40%	
	Dichloroethane	10'34"	497.5g	99.50%	
	Chloroform	8'49"	495.2g	98.98%	
	Hexane	9'27"	496.0g	99.20%	
	Trichloroethane	9'05"	495.2g	99.04%	
	Ethyl acetate	11'50"	493.0g	98.60%	
	Benzol	10'43"	497.3g	99.46%	
	Toluene	13'42"	498.9g	99.78%	
Auto mode		Concentration time	Setting temp. for vapor	Recovery amount	Recovery rate
99.63% of benzol was recovered.	Diethyl ether	12'39"	25°C	493.7g	98.74%
	Dichloromethane	10'19"	25°C	490.3g	98.06%
	Acetone	13'49"	21°C	495.6g	99.12%
	Dichloroethane	13'03"	25°C	497.8g	99.56%
	Chloroform	8'50"	21°C	489.7g	97.94%
	Hexane	10'17"	23°C	495.4g	99.08%
	Trichloroethane	10'17"	25°C	494.3g	98.86%
	Ethyl acetate	12'15"	25°C	493.4g	98.68%
	Benzene	13'22"	25°C	498.4g	99.68%
	Toluene	15'20"	25°C	499.3g	99.86%

Condition: Bath temperature: 40°C, temperature of cooling water: Approx. 5°C, Rotation number: 100rpm, Room temperature: 20~23°C  
Concentration device: Evaporator N-1001SW

Products Name	Vacuum Controller
Model Name	NVC-2100
Cat. No.	216639
Pressure Measurement Range	0 to 1065mbar(hPa), 0 to 800mmHg
Pressure Setting Range	Normal Control 0 to 1013mbar(hPa), 0 to 760mmHg
	Auto Control Auto Detection, Auto Setting
	Program Control 10 Major Solvents Programmed
	Step Program Control 0 to Atmosphere Pressure (Normal Program control)
Hysteresis Setting Range	Normal Control Auto (2%) or 1 to 20mbar (hPa), 1 to 15mmHg
	Program Control Auto (2%) 1 to 20%
Time Setting Range	Program Control: 1 to 999min, Step Program Control: 0 to 999min
Pressure Control Modes	Normal, Auto, Program, Step Program
Display	Pressure Reading, Pressure Setting, Temperature (Optional)
Automatic Leak Feature	Automatic Leak After Control (Selectable by Manual Leak)
Refresh Feature	Automatic Output After Control
Hold Feature	Maintain constant vacuum in Normal, Program, and Step Program modes
Pressure Sensor	Piezoresistance Type Pressure Sensor
Electric Leak Valve	Built-in, Orifice: 1/8" (2.4mm)
Piping Material	PPS, PP, Teflon
Nozzle Size	Diameter 3/8" (10mm)
Electric Teflon Valve for Control	Optional
Additional Power Supply	Max 6A for Diaphragm pump
Ambient Temperature	5 to 35°
Overall Dimension	5" (126mm)W x 4" (100)D x 3 1/8" (80)H
Supply Power/Power	100VA/115V 60Hz

\* In case of setting up to N-1001 rotary evaporator, setting plate, N-NVC3, (No. 189310) and CV-1 or CV-2 is required.

Model	Cat. No.	Spec.
CV-1	196910	OD10mm hose nozzle
CV-2	196920	OD13mm hose nozzle
Vapor Temp. Sensor Set	211770	N-1001S type series
	211780	N1001V/1001T type series

## Water Bath

### SB-1000 / OSB-2000

The SB-1000 is a compact Water Bath capable of heating 50ml to 1000ml evaporating flasks up to 90°C. The OSB-2000 is a water and oil bath that accommodates 50ml to 2000ml evaporating flasks, and has a 180°C heating capacity. Both baths come equipped with a digital temperature display.

Model Name	SB-1000	OSB-2000
Cat No.	188789	211739
Operating Temp. Range	5°C above ambient to 90°C	5°C above ambient to 180°C
Accuracy	+/-1.5°C	+/-1.5°C (Oil: +/-3.0°C)
Safety Feature	Independent Over Heat Protector, Fuse	
Bath Material/Capacity	SUS 304/Approx. 3 Liters	SUS 304/Approx. 7 Liters
Evaporating Flask	1 Liter Max	2 Liters Max
Power	1000VA/115V, 60Hz	
Net Weight	6.6lb(3kg)	9.9lb(4.5kg)



SB-1000



OSB-2000

## Low Temp. Circulator

### CA-1113

The CA-1113 operates between -20°C and 20°C, and performs exceptionally as a low temperature circulator for a condenser. The CA-1113 has a 900W @ 10°C cooling capacity, and holds up to 1L of liquid, allowing for steady circulation to 2 rotary evaporators.

Model Name	CA-1113
Cat. No.	219969
Circulation Method	Closed Loop System
Operating Range	-20 to 20°C
Temp. Accuracy	+/-2°C
Cooling Capacity	900 W (774 kcal/h) at 10°C
Circulating Capacity	Maximum Flow Rate: 16 Liters, Top Lift: 42.9ft(13m)
Safety Features	Residual Current Device, Refrigeration High Pressure Switch Overload Relay, Refrigerator Protection Timer, Fuse for Additional Power Plug, Self-checking Temperature Control Unit, Thermal Protector
Additional Features	Temperature Display Correction, Flow Rate Stop Valve
Pumping Nozzle Size	OD 3/8" (10.5mm)
Overall Dimension	9 1/8"W x 19 5/8"D x 33"H (232mm x 497mm x 835mm)
Net Weight	Approx. 88lb(40kg)



A-1000S

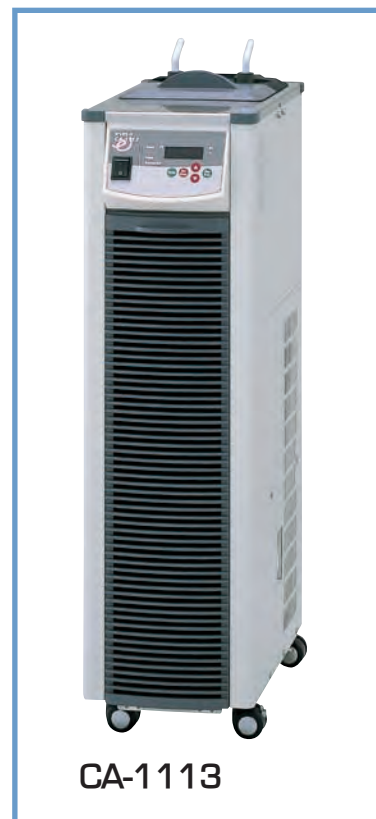

CA-1113

## Aspirator and Vacuum Pump

### A-1000S

The A-1000S provides cost-effective concentration and depressurization of water type solvents. When used in combination with a CA-1113, the system can maintain a stable and reliable vacuum.

Model Name	A1000S	MD1C	2044
Cat. No.	210539	198539	220769
Displacement	19L/min	24L/min	35L/min
Suction Nozzle	OD 3/8" (9mm)	OD 3/8" (10mm)	OD 3/8" (10mm)
Net Weight	14.3lb (6.5kg)	15lb (6.9kg)	23lb (10.4kg)

Welch



VacuuBrand

## Solvent Recovery Unit



DPE-1120

The DPE-1120 comes equipped with the NVC-2100 digital controller and a highly efficient condenser, allowing for safe and effective waste solvent recovery. An integrated recovery flask and exhaust gas absorption cartridge ensures complete waste containment.

A closed refresh function circulates excess gas between diaphragm pump and absorption cartridge, eliminating any waste gas from escaping. This function improves the life of the diaphragm pump, sensor, electromagnetic valve, and absorption cartridge, providing a more efficient and cost-effective solvent recovery system.

## Closed refresh system of a diaphragm pump and electromagnetic valve (DPE-1120)

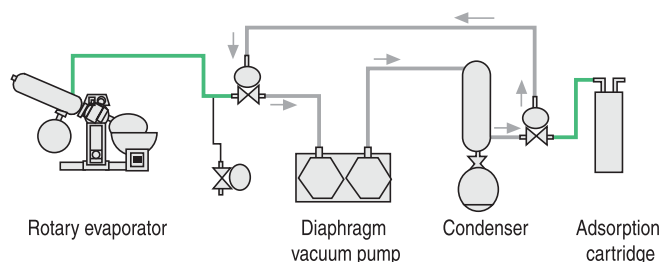

Automatically exhausting the remaining vapor a diaphragm pump is utilized in the closed system to circulate and recover the vapor into the condenser. This system improves the durability of a vacuum pump, sensor, the electromagnetic valve, and it extends the life of the absorbent cartridge.

## Solvent vapor and exhaust gas is trapped and collected



Solvent vapor exhaust emitting from the diaphragm vacuum pump can be directed into the unit for effective recovery. A cold insulation condenser further improves recovery rate.



An environmentally friendly absorption cartridge (active charcoal filter) removes any undesirable odor.

Products Name	Solvent Recovery Unit
Model Name	DPE-1120
Cat. No.	216659
Pressure Measurement Range	0 to 1065mbar(hPa), 0 to 800mmHg
Pressure Setting Range	Normal Control: 1 to 1013mbar(hPa), 1 to 760mmHg Program Control: 1 to 933mbar(hPa), 1 to 700mmHg
Hysteresis Setting Range	Normal Control: Auto (2%) or 1 to 20 mbar(hPa), 1 to 15mmHg Program Control: Auto (2%) or 1 to 20%
Control Modes	Normal, Auto, Program and Step Program
Display	LCD Digital Display (Mode, Pressure Reading, Pressure Setting, Temperature (Optional))
Pump Control	Automatic ON-OFF Interlocking Pressure, Cleaning Action
Exhaust Gas Trapping Features	Closed Refresh System, Cartridge Adsorption
Electric Valve for Pressure Control	Teflon Diaphragm Electric Valve
Piping Material	Glass, PP, Teflon, Viton
Receiving Containers	Waste Liquid Trap:400ml, Receiving Flask:500ml (Max. 1 Liter)
Nozzle Size	Diameter 3/8"(10mm) for Duct, Leak, Circulate, Exhaust
Hold Feature	Maintain constant vacuum in Normal, Program, and Step Program modes
Vacuum Pump	10 to 40 Liters Diaphragm Pump
Additional Power Plug	AC115V 6A for Diaphragm Pump
Ambient Temperature	5 to 35°C
Overall Dimension	7 7/8"(198mm)W x 15"(380)D x 19 1/8"(485)H
Supply Power/Power	100VA/115V 60Hz

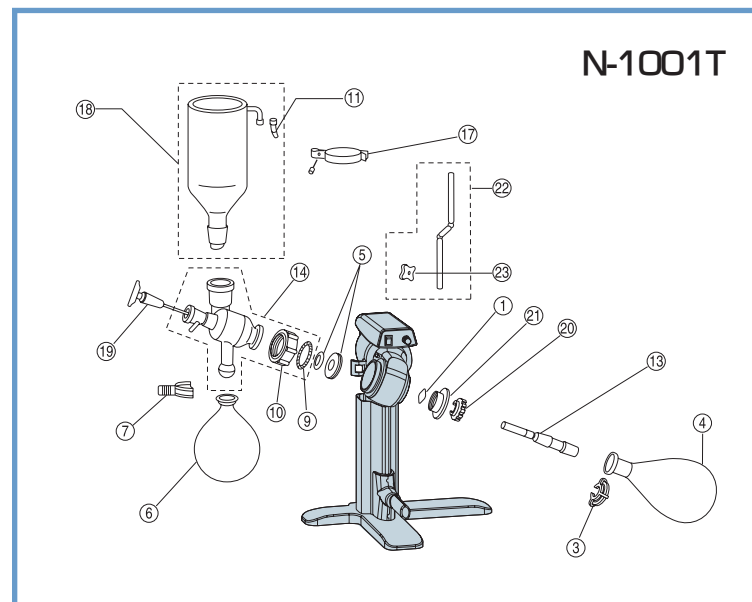
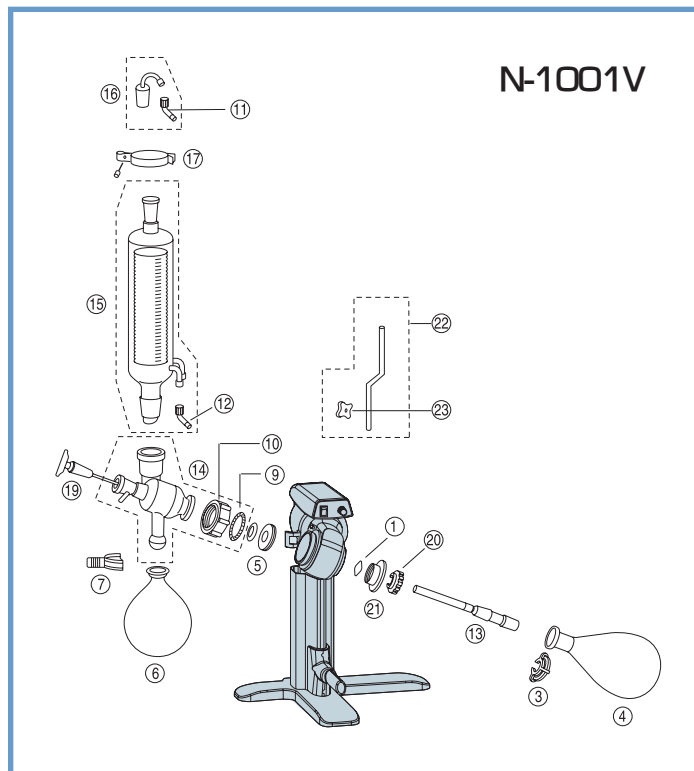
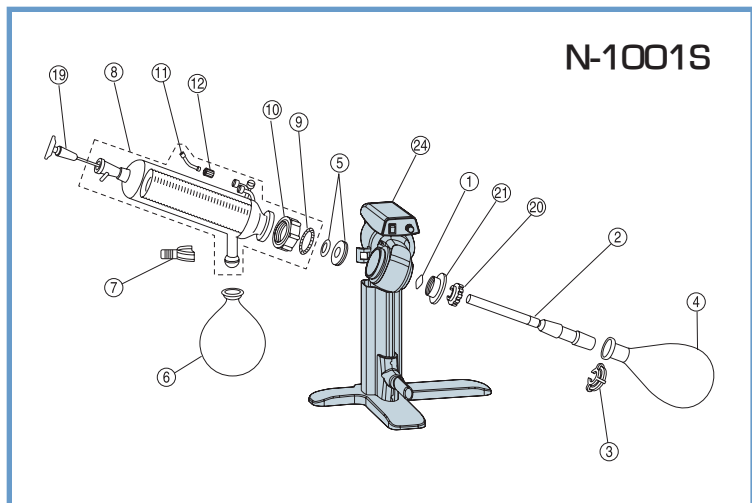

Tip: Seal replacement is suggested every 6 months for demanding users.  
Cat No. 142610



No	Parts Name	Specification	Pcs	Cat. No.
1	Sleeve Pin		2	142650
2	Rotary Joint (Vapor Duct)	272mm NS 24/40	1	142510
3	EYELA Clip	NS 24/40	2	142550
4	Evaporating Flask	1000ml NS 24/40	1	216840
5	Vacuum Seal		2 sets	142610
6	Receiving Flask	1000ml S35/20	1	216890
7	Ball Joint Clamp	S35	1	202790
8	Diagonal Condenser	N-1001S	1	187780
9	Ring Spring		1	142710
10	Cap Screw		1	142700
11	Vacuum Nozzle Set (White)		3 sets	142690
12	Cooling Water Nozzle Set (Light Blue)		2 sets	178900
13	Rotary Joint (Vapor Duct)	178mm NS 24/40	1	142530
14	Adapter	For V/T Model	1	911160
15	Vertical Condenser	N-1001V	1	187790
16	Suction Cock		1	142620
17	Condenser Holder		1	185240
18	Dewar Condenser	N-1001T	1	187920
19	Inlet Feed Tube	NS 19/40 Teflon Tube	1	116540
20	Rotary Joint Ring	NS 24/40	2	217020
21	Flask Remover		1	192610
22	Condenser Support Bar	V, T Models	1	192620
23	Knob Bolt	V, T Models	1	195060
24	N-1001 Main Body		1	213399





## Precision Design Meets Higher Capacity

- An equipped drain valve on the receiving flask enables the user to easily recover the condensed liquid while maintaining low pressure.
- Vacuum controller enables user to regulate pressure precisely while increasing the recovery rate and improve efficiency.
- New and improved vacuum seal enables the user to maintain a higher vacuum in the system.
- A “one-touch” clamp on the sample flask allows the user to easily attach and detach the flask.
- Digital temperature and rotation speed displays allow the user to reproduce evaporation conditions very accurately.

Products Name	Rotary Evaporator
Model Name	N-3000
Cat. No.	221129
Rotation Speed	10-130rpm (Variable Speed)
Evaporating Capacity	Max 3.5 L/h (Water)
Ultimate Vacuum	1.333mbar(1 Torr) or less
Bath Temp. Range	10°C to 180°C above ambient
Accuracy	+/-1°C (Oil: +/- 3°C) at Rotating flask
Temperature Control	P.I.D. Control
Safety Features	Overflow Pipe, Thermal Low Liquid Level Protector Independent Over Temperature Cut Off, Limited Switch for Bath's Up and Down, Motor Fuse, Breaker
Display	Digital Bath temperature and sample flask rotational speed display
Jack Feature	Electric Automatic Jack
Vacuum Control Features	Fixed-point control (1-760mmHg/1-1013hPa), auto control (optional temp. sensor), programmed controller for common solvents, step controller
Heater	Temperature Control: 3.5 kW
Motor	Induction Motor 60W
Condenser	Diagonal Triple Coil, Cooling Surface 0.5m <sup>2</sup>
Evaporating Flask	Round Shaped Flask 10 Liters, Bore Dimension:4"(100mm)
Receiving Flask	5L Round Shaped Receiving Flask with Drain Valve
Vacuum Seal	Mechanical Seal
Bath Size/Capacity/Material	Diameter 14 1/4"(360mm) x 7 7/8"(200mm)H, 20 Liters, SUS 304
Suction & Circulate Diameter	Suction and Circulate Nozzle OD:5/8"(16mm)
Jack Stroke	5 3/4" (141mm)
Ambient Temperature	5 to 35°C
Overall Dimensions	36 5/8"W x 17 3/4"D x 74 3/8"H 930mmW x 450mmD x 1890mmH
Net Weight	Approx. 211lb(96kg)
Supply Power/Power	3800VA/220V, single phase, 60Hz



Operating Portion

One-touch Clamp



The user-friendly sample flask clamp makes attachment and detachment of the sample flask easy.

Receiving Flask Drain Valve



This convenient drain valve allows the user to remove condensed liquids during evaporation operation.

Large Bore Diameter Evaporating Flask



Sample removal and cleaning made easy.

Improved Vacuum Seal



New and improved mechanical vacuum seal is more durable and maintains low pressure more effectively.

Safety Feature



Independent over heat protector, thermal low liquid level protector and over flow pipe are included.

Figures mentioned here are measured in a room temperature environment at 20 °C. Evaporation capability varies depending on bath temperature and the water temperature. Range of temperature control differs depending on ambient temperature, amount of evaporation and other conditions. Main connector is not included.

# Rotary Evaporator Accessories

## Rotary Joint (Vapor Duct)

Eyela's strict quality control production ensures stable performance.



Cat No.	Length (inch)	Length (mm)	N/S Size
216770	10 3/4"	272	NS 29/32
142510*	10 3/4"	272	NS 24/40
216780	7"	178	NS 29/32
142530*	7"	178	NS 24/40

\* It is equipped with Rotary Evaporator N-1001 series as standard.

## Evaporating Flask

Eyela's evaporating flasks have been produced through strict quality control. It forms few bubbles during experimentation, and can be used even in high rotation speed or high vacuum applications.



Evaporating flask NS 29/32			Evaporating flask NS 24/40		
Cat No.	Capacity	Qty	Cat No.	Capacity	Qty
216700	50ml	1	216800	50ml	1
216710	100ml	1	216810	100ml	1
216720	250ml	1	216820	250ml	1
216730	500ml	1	216830	500ml	1
216740	1000ml	1	216840*	1000ml	1
216750	2000ml	1	216850	2000ml	1

\* It is equipped with Rotary Evaporator N-1001 series as standard.

## Receiving Flask



Cat. No.	Capacity	Spec.	Qty
216860	100ml	Ball Joint S35/20	1
216870	250ml	Ball Joint S35/20	1
216880	500ml	Ball Joint S35/20	1
216890*	1000ml	Ball Joint S35/20	1
216900	2000ml	Ball Joint S35/20	1

\* It is equipped with Rotary Evaporator N-1001 series as standard.

## Trap Ball

In case of bumping, the trap ball prevents the sample from flowing back or mixing into recovery flask. EYELA's trap ball ensures stable performance. Adapters are available.



Cat. No.	Capacity	Spec.	Qty	Cat. No.	Capacity	Spec.	Qty
116730	100ml	NS 24/40 x 24/40	1	116830	300ml	NS 24/40 x 24/40	1
156710	100ml	NS 24/40 x 19/33	1	156660	300ml	NS 24/40 x 19/33	1
116740	100ml	NS 24/40 x 15/30	1	116840	300ml	NS 24/40 x 15/30	1
116780	200ml	NS 24/40 x 24/40	1	156630	500ml	NS 24/40 x 24/40	1
156690	200ml	NS 24/40 x 19/33	1	156640	500ml	NS 24/40 x 19/33	1
116790	200ml	NS 24/40 x 15/30	1				

## Connector



Connects different joint sizes. Various sizes are available.

For Rotary joint	
Cat No.	Spec.
116900	NS 24/40 x 29/38
116910	NS 24/40 x 19/33
116920	NS 24/40 x 15/30

## Teflon Seal



Increases performance in organic solvent applications.

Cat. No.	Qty
143880	1

## Separable Flask



### Separable Cover

For use in combination with separable evaporating flask. 50mm bore design accommodates 50ml to 300ml flasks. 75mm bore design accommodates 500ml and 1000ml flasks.



### Separable Evaporating Flask

Since the diameter of the mouth of the flask is 75mm (50mm), large dried samples can be taken out easily. Also, you can clean the flask easily after the experiment.

	Model	Cat. No.	Spec.	Mouth ID x H (inch)	Mouth ID x H (mm)
Separable cover	Y-SC-3	116470	NS 24/40	2" x 3 1/4"	50 x 82
	Y-SC-4	116490	NS 24/40	3" x 3 1/4"	75 x 82
Separable evaporating flask	Y-SC-5	116400	50ml	2" x 2 3/8"	50 x 60
	Y-SF-10	116410	100ml	2" x 4"	50 x 100
	Y-SF-20	116420	200ml	2" x 4 3/8"	50 x 110
	Y-SF-30	116430	300ml	2" x 4 7/8"	50 x 125
	Y-SF-50	116440	500ml	3" x 6"	75 x 152
	Y-SF-100	116450	1000ml	3" x 7 1/4"	75 x 185

## Separable Clamp

Secures separable flask to cover. Designed with no protruding elements.



Model	Y-SK-24	Y-SK-13
Cat. No.	116510	116500
Separable Flask Capacity	500, 1000ml	50 to 300ml
Applicable mouth size	75mm	50mm

## Separable Tool Packing

Highly resistant to chemicals. Level of vacuum is maintained when in use with a separable clamp.



Model	Y-SS-24	Y-SS-13
Cat. No.	116530	116520
Separable Flask Capacity	500, 1000ml	50 to 300ml
Applicable mouth size	75mm	50mm

## Glass Capillary (Inlet Feed Tube)

For use with consecutive injections. Allows for no contact with vapor duct and no resin influence.



Applicable model	Cat. No.	Spec.
N-1001S, V, T	116540*	27" (685mm) NS 19/40 Teflon tube
N-1001S	142590	20 1/8" (510mm) NS 19/40
N-1001V, T	142600	11 3/4" (297mm) NS 19/40

\* It is equipped with Rotary Evaporator N-1001 series as standard.

## Glass Stopper



Designed with no infusion pipe for consecutive injection, effectively preventing backflow of condensate.

Cat. No.	Qty
116970	1

## Three-way Cock



Enables recovery of distillate liquid inside the receiving flask during operation.

Cat. No.	Qty
116960	1

## Cold Insulation Hose Set



Prevents dew condensation and circulates cooling water while ensuring no increase in water temperature.

Tube diameter	Cat. No.	Length	Cat. No.	Length
ID 3/8" (9mm)	112700	2m	174420	5m
ID 5/8" (15mm)	143340	2m	174460	5m

## Vacuum Hose



Decreases pressure in compact evaporator and small condenser applications.

Tube diameter	Cat. No.	Length
ID 1/4" x 5/8" (6 x 15mm)	119170	5m
ID 1/2" x 1 1/8" (12 x 30mm)	119210	5m

# EYELA

<http://www.eyelusa.com>

## EYELA

**TOKYO RIKAKIKAI CO., LTD**

<http://www.eyelusa.com>

[info@eyelusa.com](mailto:info@eyelusa.com)

### US OFFICE

15375 Barranca Parkway, Suite J-104

Irvine, California 92618

Phone: 949-453-0011

Fax: 949-453-0008

### HEAD OFFICE

Nihonbashi Hon-cho Bldg. 3-3-4

Hon-cho Nihonbashi, Chuo-ku

Tokyo, 103 - 0023, Japan

Phone: 81/3-5201-6462

Fax: 81/3-3245-1225



**Safety  
precaution**

For your safety, please read the  
Instruction manual carefully before  
operating the product.