

Aquatron

Automatic Water Stills

A4000 A8000 & A4000D

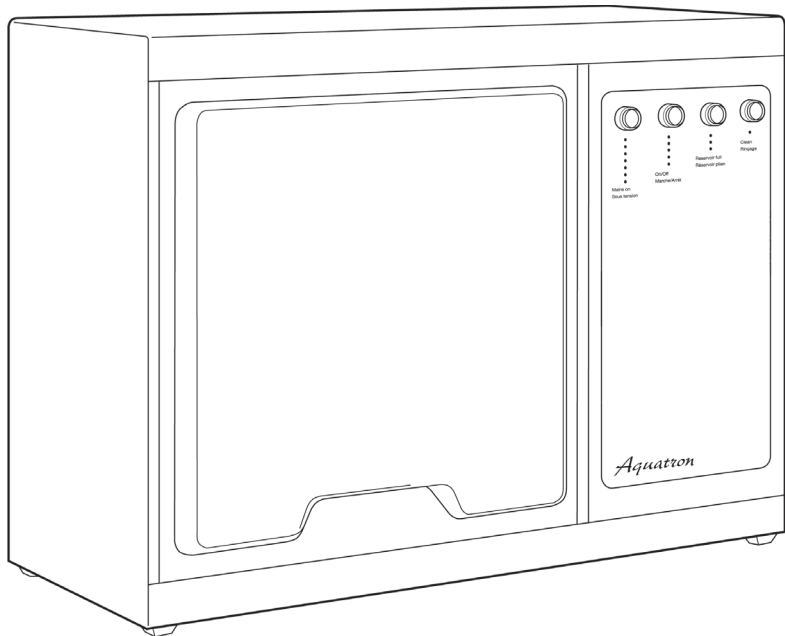

Assembly and
operating instructions

Contents

Location and Services required for A4000, A8000 and A4000D	1
A4000 Aquatron (4 litre/hr, single distillation)	2
Assembly	3
Operation	5
A8000 Aquatron (8 litre/hr, single distillation)	6
Assembly	7
Operation	9
A4000D Aquatron (4 litre/hr, double distillation)	10
Assembly	11
Operation	13
Distillate collection and reservoir system	14
Connection of Stills to deionisers and pre-treated water supplies	15
Cleaning Instructions	16
Fault Finding	17
List of Spares	18
Circuit & Wiring Diagrams	19



The Aquatron Water Still complies with the following European Directives:
89/336/EEC - E.M.C. DIRECTIVE
Amended by 92/31/EEC and 93/68/EEC
73/23/EEC - L.V.D. Amended by 93/68/EEC

Limitations of use

This product meets the applicable E.C. harmonised standards for radio frequency interference and may be expected not to interfere with, or be affected by other equipment with similar qualifications. We cannot be sure that other equipment used in its vicinity will meet these standards and we cannot guarantee that interference will not occur in practice. Where there is a possibility that injury, damage or loss might occur if equipment malfunctions due to radio frequency interference, or for general advice before use, please contact the Technical Service Department of Bibby Scientific Ltd.

Location & Services

A4000, A8000, A4000D

In order to obtain the optimum performance from your new Aquatron careful consideration should be given to the intended location and the availability of services such as water, electricity and drain.

Please study the following notes before commencing installation.

Before Use

If the equipment is not used in the manner described in this manual then its performance and operation will be impaired.

Aquatron water stills are designed to operate under the following conditions:

- ❖ For indoor use only.
- ❖ Ambient temperature +5°C to +40°C.
- ❖ Altitude up to 2000M.
- ❖ Relative humidity not exceeding 80%.
- ❖ Mains supply voltage fluctuates not greater than ±10% of normal.
- ❖ Over voltage Category II IEC60364-4-443.
- ❖ Polluting degree 2 IEC664.

1 Bench Wall Mounting

Aquatron models A4000 and A8000 can be either bench or wall mounted and a bracket is provided for the latter purpose. A gap of at least 50cm should be left at the right hand end of the unit to allow access to the heating elements.

For reasons of weight, models A4000D and A8000 are best bench mounted, but if it is desired to elevate the unit then a stout shelf should be used.

2 Electricity Supply

N.B. The Aquatron Water Still is classified as "Permanently Connected Equipment" and should be connected to the electricity supply by a qualified electrician in the manner described in the electrical installation section of this manual.

The Aquatron stills are available in three models, A4000, A4000D & A8000.

A suitable supply for the A4000 is rated at 3kW, 220-240v, 50/60Hz~ single phase. A suitable supply for the A4000D & A8000 is rated at 6kW, 220-240v, 50/60Hz~ single phase. A 30mA RCD mains isolation unit should be used to isolate the Water Still from the mains supply.

If you have any doubts about the suitability of your supply, consult a qualified electrician before installing your Aquatron still.

3 Water Supply

A cold water supply is required for coolant and feed purposes. This may be from the mains supply or a header tank having a flow capacity of at least 1 litre/min. for the A4000 and 2 litres/min. for the A8000 and A4000D. The pressure range should be within 3-100 p.s.i. ($0.2-7 \times 10^5 \text{Nm}^{-2}$).

If the feed water quality is poor and likely to contain particulate matter, such as rust or silt, it is advisable to fit a pre-filter unit before the still.

4 Drain

A waste water drain is required. It is important that the distance between the drain and the water still is kept as short as possible to reduce the possibility of pressure build-up. Similarly, the drain pipe from the still should fall straight, without any kinks or bends, to allow an unimpeded flow. It is also recommended that the unit is connected to properly earth bonded water supplies and drainage systems.

5 Storage Tank

A suitable reservoir, the WR20 for instance, is required for the collection of the distillate. This should be positioned beneath the still ensuring that the distillate can flow into the reservoir without hindrance.

6 Maintenance

The location of the still should facilitate easy access for routine cleaning and maintenance. With regards to the latter, it is recommended that a space of at least 50cm be provided on the right hand side of the water still cabinet. This is to allow the removal of the side cover and replacement of the heating element.

7 Warranty

Bibby Scientific Ltd warrants this instrument to be free from defects in material and workmanship, when used under normal laboratory conditions, for a period of **three (3)** years. In the event of a justified claim Bibby Scientific will replace any defective component or replace the unit free of charge.

This warranty does NOT apply if damage is caused by fire, accident, misuse, neglect, incorrect adjustment or repair, damage caused by incorrect installation, adaptation, modification, fitting of non approved parts or repair by unauthorised personnel.

This Warranty does not include the heater element which is only guaranteed for up to 1000 hours in use.

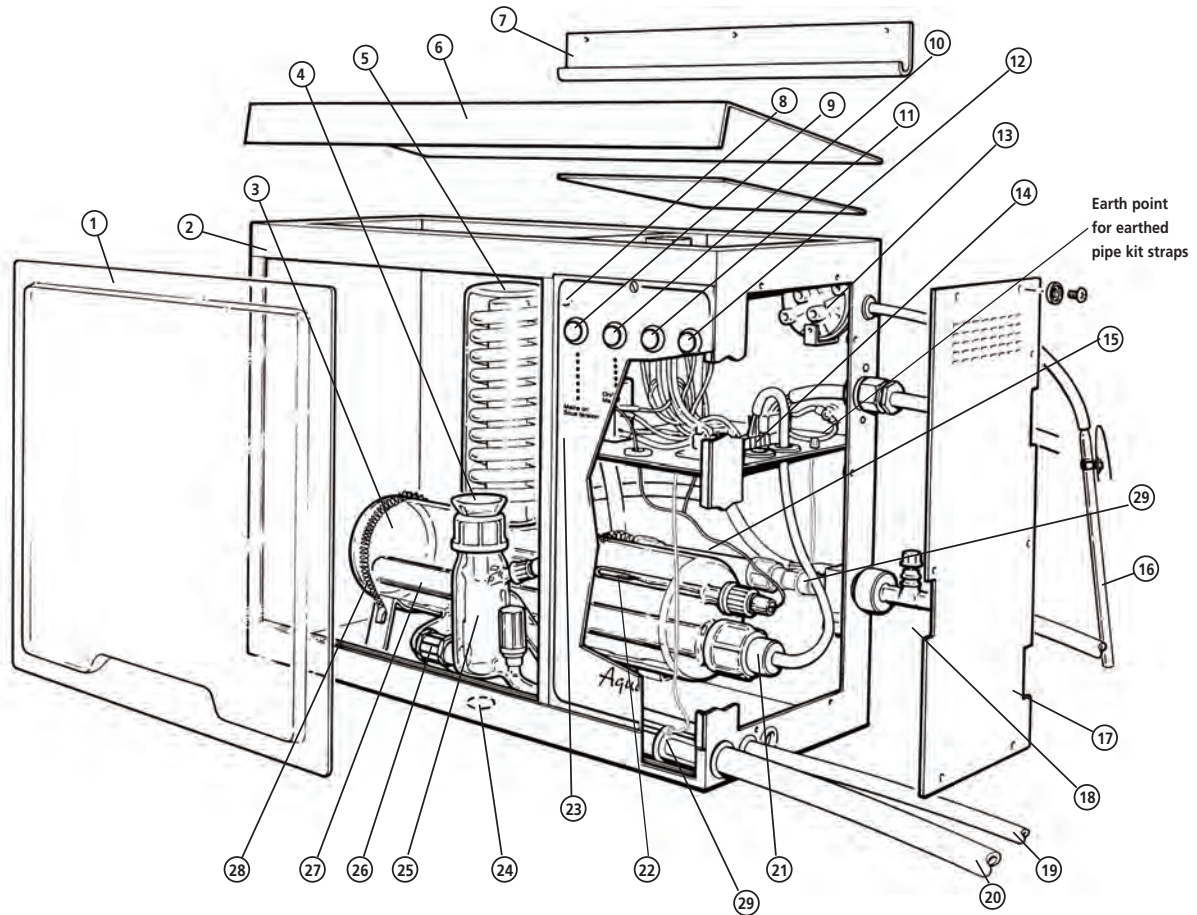

Fig 1: Major component parts A4000

List of Major Components – A4000

Item no.	Description	Part number	Item no.	Description	Part number
1	Perspex Screen	M484	15	Water Flow Control Switch	I/A4000HK/1
2	Cabinet	M510	16	Reservoir Level Control	I/D4000/WLS
3	Boiler	WB4	17	Cabinet End Plate	M510B
4	Funnel	WF48	18	Mains Water Inlet with Needle Valve	7001059 (S)
5	Condenser	WC48/M2	19	Distillate Outlet Pipe (Bench Mounted)	–
6	Cabinet Roof	M510A	20	Cooling Water Pipe to Drain	–
7	Wall Mounting Bracket	M510G	21	Thermostat Glass Tube	WTT48
8	Dummy Shorting Plug	–	22	Thermostat	WT4
9	Green 'Mains On' Indicator	700691 (S)	23	Thermostat Re-set Button	WT4
10	White 'On/Off' Switch	700988 (S)	24	Distillate Outlet (Wall Mounted)	–
11	Amber 'Reservoir Full' Indicator	700987	25	Boiler Level Control	WL48
12	White 'Clean' Switch	700988 (S)	26	Boiler Plastic Coupling	WBC1
13	Reservoir Pressure Switch	WPS	27	Heating Element	W48H
14	Terminal Strip for Heater Connection	700670(S)	28	Boiler Retaining Springs	–
			29	Earthed pipe kit	A4000/EK

A4000 Assembly

Your Aquatron A4000 has been designed with ease of assembly specifically in mind, but before commencing assembly please study the illustration, fig. 1 on page 2 to familiarise yourself with the general lay-out. During assembly, follow the sequence of instructions and do not connect the mains electricity supply until directed.

- 1 From the outer packaging remove all the components including the metal cabinet containing the glass boiler.
- 2 Before unpacking the individual components, identify them on the check-list below.
- 3 Remove the perspex viewing screen, item 1 fig. 1 by using the finger recess to lift the screen out of the lower cabinet groove, then remove the internal packaging which has protected the glass boiler during transit. Also sever the temporary tie holding the two boiler retaining springs, item 28 in place.

- 4 Remove the cabinet end plate, item 17 by unscrewing the six retaining screws and 'shake proof washers'. Similarly, unscrew the six countersunk screws to remove the cabinet roof (item 6).

- 5 Ensure that the sealing o-ring and stabilising o-ring are correctly positioned, as shown in Figure 3a. Fit the condenser WC48/M2 by mounting it onto the vapour tube of the boiler. Ensure the distillate outlet tube of the condenser faces the front and the cooling outlet faces parallel to the unit.

- 6 Refer to fig. 2. From the bag of hoses take the 1000mm length of 8mm diameter vinyl tubing and connect it to the distillate outlet tube of the condenser. Secure with a tie strap.

- 7 Pass the free end of the vinyl tubing through the orifice in:-
 - i) the cabinet base, item 24, if the A4000 is to be wall mounted.
 - ii) the cabinet side, item 19, if bench mounted.

- 8 Take the 1000mm length of 16mm tubing and push through the larger of the three holes, item 20, on the side of the cabinet. This may be easier if the tubing is lubricated by wetting it with water. Continue until the tube extends approximately 250mm into the main chamber, roughly level with the outlet of the condenser.

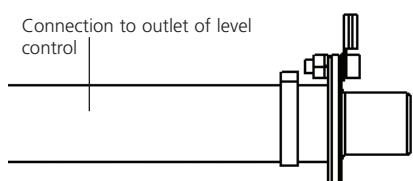

Figure 2a: Hose assembly 1

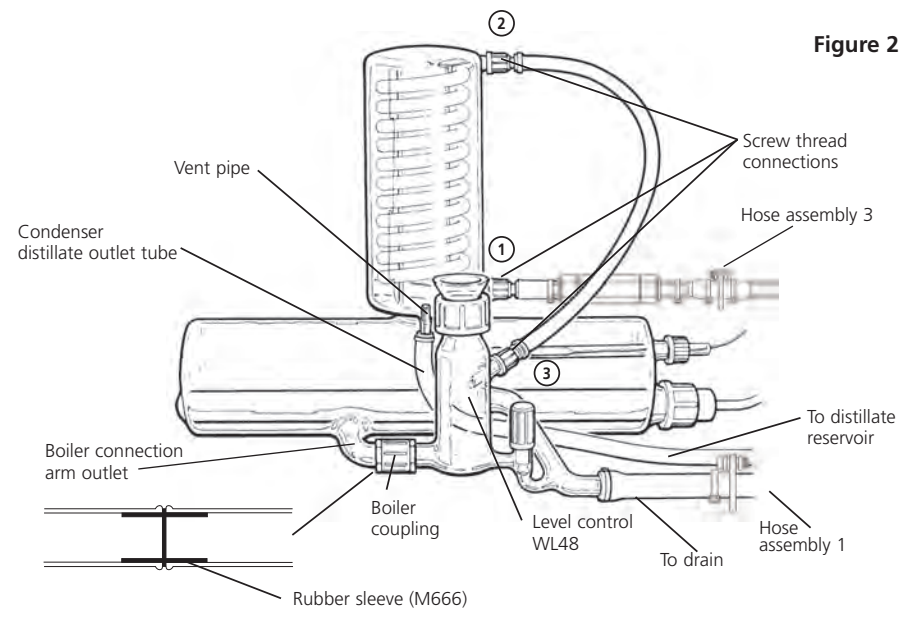

Figure 2

Item No.	Description	Part No.	Qty.
5	Condenser	WC48/M2	1
27	Heater	W48H	1
25	Boiler Level Control	WL48	1
4	Funnel	WF48	1
16	Reservoir Level Control	I/D4000/WLS	1
7	Wall Mounting Bracket	M510G	1
-	Bag of plastic hoses & tie straps	WH48/1	1
29	Earthed pipe kit	A4000/EK	1

- 9 Refer to fig. 2a. Connect the 16mm tubing to the earthed spigot of hose assembly 1 hose and secure with a tie-strap.
- 10 Connect the open end of the 16mm tubing of hose assembly 1 to the outlet of the level control WL48 and secure with a tie-strap.
Ensure that the Rotaflo PTFE stopcock of the WL48 is closed.

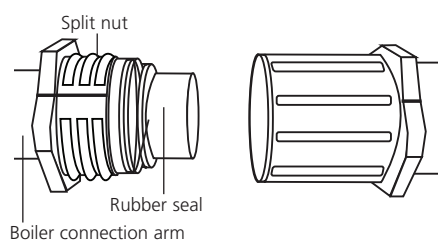

Figure 2b: Boiler coupling

- 11 Refer to fig. 2b. Undo the split nut from the coupling. Open the split plastic nut and place on the outlet of the boiler connection arm. Attach level control to boiler connection arm ensuring rubber seal is in position. Secure by screwing split nut into boiler plastic coupling.

- 12 Unscrew the black plastic screwcap from the WL48 and assemble the glass funnel WF48 – item 4.

- 13 Looking inside the cabinet, identify the vinyl tubing assembly fitted with 3 numbered screwthread connectors. Referring to illustration fig. 2 make the following connections:-

Connector No. 1 to lower water inlet of the condenser.

Connector No. 2 to upper water outlet of the condenser.

Connector No. 3 to boiler level control WL48.

- 14 Unscrew the black plastic screwcap, and rubber ring, from the boiler. (W48H, item 27). Insert the heater into the boiler ensuring that the end is supported in the glass nodule of the boiler.

Do not over-tighten the screwcap as this may cause the boiler to break or push the heater in too far as this may break the nodule.

- 15 Pass the electric cable of the heater up into the electrical control compartment via the available orifice. Push the spade terminals onto the correct pins of the connecting strip (refer to fig. 1 and fig. 3).

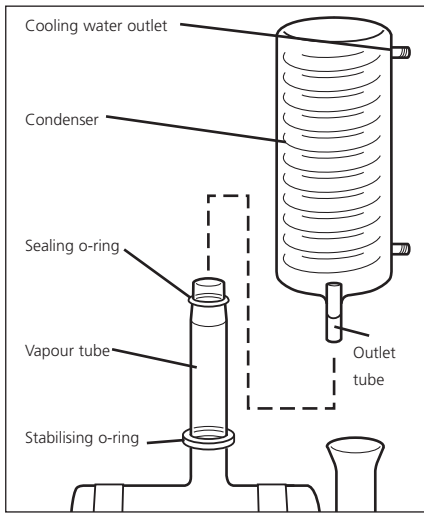

Figure 3a

- Blue - neutral
- Brown - live
- Earth - yellow/green

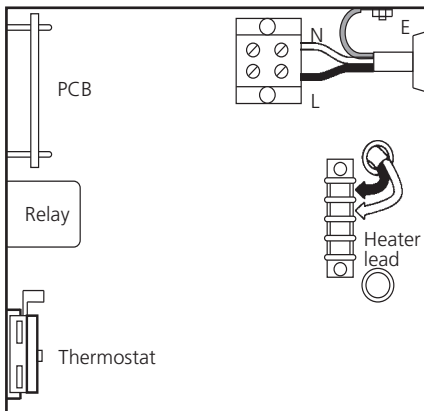

Figure 3 Termination for A4000

- 16 Refit the cabinet end panel with all six screws and washers and the cabinet roof with all six counter sunk screws. Replace the perspex viewing screen.

You have now assembled your Aquatron Water Still. Move the assembled A4000 to its working location - using the mounting bracket, item 7 if the unit is to be wall mounted. Ensure there is a space of at least 50cm to the right of the unit to allow access to the heating element.

- 17 Connect the cold water supply to the mains water inlet, item 18, fig. 1. Note the tubing selected should have a safe working pressure of at least equal to the pressure of the water supply and should be adequately secured by hose clips. Check to ensure that the two earth wires from hose assembly 1 and 3 are connected to the earth point as shown in fig. 1 and 20.

DO NOT TURN ON WATER SUPPLY.

- 18 **Electrical Installation**

THIS EQUIPMENT MUST BE EARTHED!

The electrical installation should only be carried out by a qualified electrician.

The A4000 is classed as permanently connected equipment.

The earthed spigots should pass a high current (i.e. >200mA) earth continuity test.

The equipment is supplied with 1.5m of flexible, triple core, circular cable to the following specification:- 1.5mm², to BS 6500 or equivalent and <HAR> or BASEC approved.

Connection to the mains electrical supply, should be via a double pole 30mA RCD isolation breaker switch with a continuous current carrying capacity of 15A at 250v. and overcurrent protection of 15A.

These devices should be sited near to the equipment and clearly marked – “Disconnect device for Aquatron Water Still”

The colour code for the mains cable is:-

- Brown – Live
- Blue – Neutral
- Yellow/Green – Earth

Mains Cable Replacement

If the mains cable requires replacement, only specially prepared spare mains lead obtained from Bibby Scientific should be used.

DO NOT SWITCH ON ELECTRICITY SUPPLY.

- 19 Connect the reservoir level control I/D4000/WLS as detailed on page 14 of the manual.
- 20 Refer to page 5 for operating instructions.

Replacing earthed hose assemblies

1. For hose assembly 1 follow the fitting instructions from 8 to 10.
2. Ensure that the earth wire is connected correctly to the earth post - see figs 1 and 3b.
3. For hose assembly 3 connect the 8mm tubing from the spigot and to the water flow control switch secure with a tie-strap. Connect the free end to the mains water inlet valve and secure with tie-straps. See figs. 2 and 3c.
4. Ensure that the earth wire is connected to the earth post - see figs. 1 and 3b.

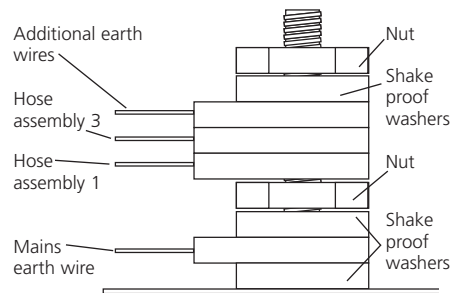

Figure 3b Earth port connection

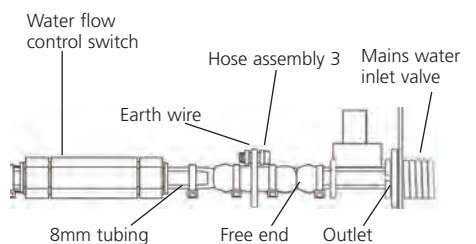

Figure 3c Hose assembly 3

A4000 Operation

The following instructions apply to the A4000 water still where the water feed to the boiler is via the mains supply, or a header tank.

If the boiler is to be fed with either de-ionised or pre-treated water, please follow the instructions on page 15.

- 1 Before switching on either the mains electricity or water supply, identify the control switches and indicator lights on the front of the cabinet.

Green Light

When illuminated this shows that there is mains supply voltage to the unit. Under no circumstances should the cabinet end-panel be removed when this light is illuminated.

White "On Off" Switch

This is the primary switch for controlling water and electricity inside the still. The switch illuminates when pressed in the ON position.

Amber Light

When illuminated, this indicates that the distillate collection reservoir is full as detected by the level control.

White "Clean" Switch

This shuts off the heating element but allows water to flow into the boiler when the still is being commissioned or cleaned. When pressed in the CLEAN position the switch illuminates.

- 2 Carefully check the following:-
 - the appropriate electricity, water and drain services have been provided. If in doubt, consult the LOCATION & SERVICES section on page 1.
 - the ON/OFF switch on the control panel is in the OFF position.
 - the CLEAN switch is pressed in the CLEAN position.
 - the RotaFlo stopcock on the boiler level control WL48 is closed.
 - the Reservoir pressure switch is fitted to the distillate collection vessel.
 - the dummy shorting plug is fitted to socket item 8, fig. 1.

Ensure the earthed pipe kit is assembled correctly and the provided earth strap is securely fastened to the main case at the correct earth point.

Check all glassware for any damage, such as chips, breaks or cracks.

- 3 Switch on the electricity supply – the green indicator light will illuminate.
- 4 Press the ON/OFF switch to the ON position – the switch will illuminate.
- 5 Recheck that the CLEAN switch is in the CLEAN position and illuminated.
- 6 Turn on the mains water supply and using the needle valve item 18 fig. 1 on the side of the cabinet, adjust the flow rate to approximately 1 litre/min.

Check that there are no water leaks from the hose connections.

- 7 Observe that the boiler is now filling with water to cover the heating element. When the water has reached the pre-set level, the excess will be discharged to drain. Check that the drain water flows freely and does not "back-up" into the level control.

- 8 Switch the CLEAN button off by pressing it for a second time – the switch light goes out.

The heater will start to warm up and eventually run at a red glow. If the flow rate is insufficient, then the heater will not switch on – this will require the control needle valve to be opened further. After about 2 to 3 mins. of operation distilled water will emerge from the outlet pipe, falling into the collection reservoir.

- 9 To avoid excessive wastage of coolant water, make further adjustments to the needle valve. Slowly reduce the flow-rate until the flow control switch, item 15, switches off the heaters – then increase the flow until the power is restored.

- 10 Refit the perspex viewing screen.

11 Safety Cut-Outs

All Aquatron water stills are protected by the following safety devices.

Flow Control Switch (item 15)

monitors the flow of coolant water into the still and shuts off the heating element, if the flow is insufficient.

Thermostat Cut-Out (item 22)

In normal operation the water within the glass will be at 100°C. In single fault conditions, i.e. in the event of water supply failure, the content will increase to 110°C where upon a resettable thermostat will operate.

Once switched, the thermostat has to be manually reset. This is achieved by unscrewing the black knob, fig. 1, item 23, located inside the cabinet and pressing the reset button.

Reservoir Control (fig. 11)

is positioned on the collection reservoir and switches off both the electricity and water supply when the reservoir is full of distilled water. The water supply is only shut off around 7 minutes after the reservoir is full to allow the heating element to cool.

It is recommended that the operation of the flow switch and reservoir control be checked on a regular basis.

a) Simulation of Mains Water Supply Failure

Turn off the mains water supply at the tap. This should switch off the heating element. Turning the tap on again will switch the heater on.

b) Simulation of Reservoir Full Condition

Lower the glass pressure bell WPB, (fig. 11), into the distillate to a depth of 150mm. This will switch off the heating element immediately and the cooling water after 7 minutes. Raising the bell will cause both to be re-supplied.

12 Switching Off

Push the CLEAN switch to the ON position. Wait until the residual heat contained in the heating element has dispersed and no boiling is evident. Turn off water supply. Push ON/OFF switch to OFF position. Isolate from mains electricity supply.

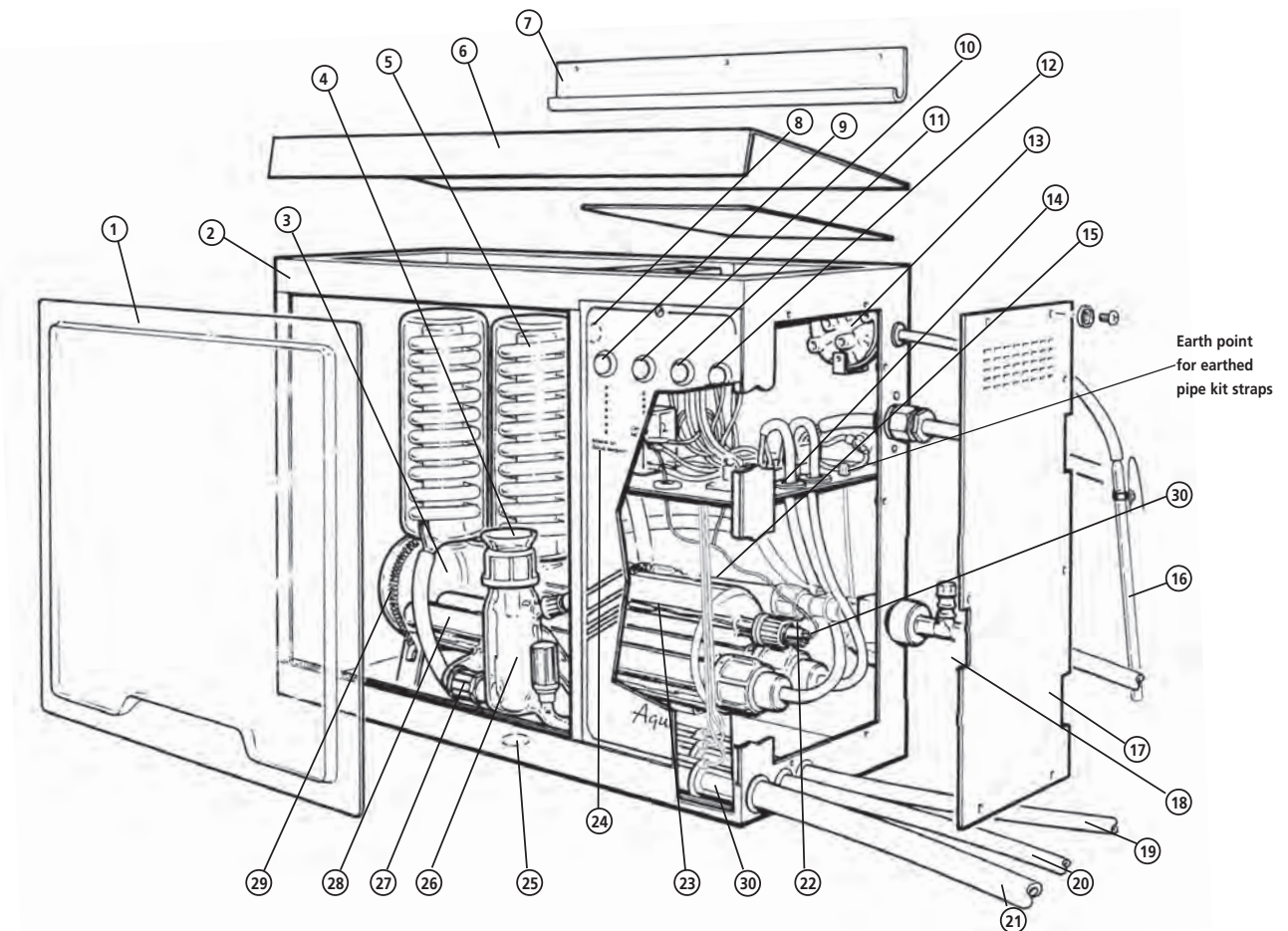

Fig 4: Major component parts A8000

List of Major Components – A8000

Item no.	Description	Catalogue number	Item no.	Description	Catalogue number
1	Perspex Screen	M484	16	Reservoir Level Control	I/D4000/WLS
2	Cabinet	M570	17	Cabinet End Plate	M510B
3	Boiler	WB8	18	Mains Water Inlet with Needle Valve	7001059 (S)
4	Funnel	WF48	19	Distillate Outlet Pipe (Bench Mounted)	–
5	Condenser (2 off)	WC48/M2	20	Cooling Water Pipe to Drain (8mm)	–
6	Cabinet Roof	M510A	21	Cooling Water Pipe to Drain (16mm)	–
7	Wall Mounting Bracket	M510G	22	Thermostat Glass Tube	WTT48
8	Dummy Shorting Plug	–	23	Thermostat	WT8
9	Green 'Mains On' Indicator	700691 (S)	24	Thermostat Re-set Button	WT8
10	White 'On/Off' Switch	700988 (S)	25	Distillate Outlet Pipe (Wall Mounted)	–
11	Amber 'Reservoir Full' Indicator	700987	26	Boiler Level Control	WL48
12	White 'Clean' Switch	700988 (S)	27	Boiler Plastic Coupling	WBC1
13	Reservoir Pressure Switch	WPS	28	Heating Element (2 off)	W48H
14	Terminal Strip for Heater Connection	700670 (S)	29	Boiler Retaining Springs	–
15	Water Flow Control Switch	I/A8000HK/1	30	Earthed pipe kit	A8000/EK

A8000 Assembly

Your Aquatron A8000 has been designed with ease of assembly specifically in mind, but before commencing assembly please study the illustration, fig. 4 on page 6 to familiarise yourself with the general lay-out. During assembly, follow the sequence of instructions and do not connect the mains electricity supply until directed.

- 1 From the outer packaging remove all the components including the metal cabinet containing the glass boiler.
- 2 Before unpacking the individual components, identify them on the check-list below.
- 3 Remove the perspex viewing screen, item 1 fig. 4 by using the finger recess to lift the screen out of the lower cabinet groove, then remove the internal packaging which has protected the glass boiler during transit. Also sever the temporary tie holding the two boiler retaining springs, item 29 in place.
- 4 Remove the cabinet end plate, item 17 by unscrewing the six retaining screws and 'shake proof washers'. Similarly, unscrew the six countersunk screws to remove the cabinet roof (item 6).

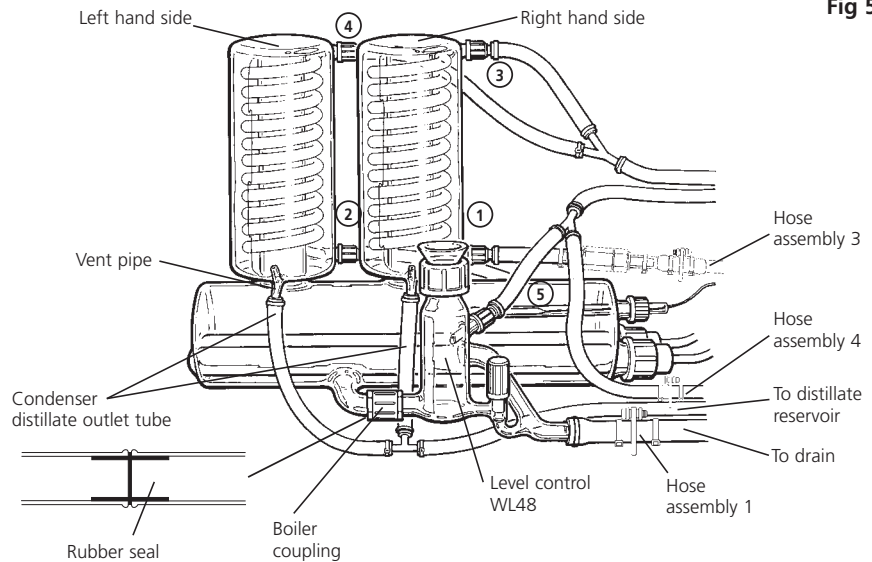

Item No.	Description	Catalogue No.	Qty.
5	Condenser	WC48/M2	2
28	Heater	W48H	2
26	Boiler Level Control	WL48	1
4	Funnel	WF48	1
16	Reservoir Level Control	I/D4000/WLS	1
7	Wall Mounting Bracket	M510G	1
-	Bag of plastic hoses & tie straps	WH48/2	1
29	Earthed pipe kit	A8000/EK	1

- 5 Ensure that the sealing o-ring and stabilising o-ring are correctly positioned, as shown in Figure 3a. Position one of the condensers WC48/M2 onto the left hand vapour tube of the boiler with the distillate outlet tube facing the front. See fig. 5.
- 6 Looking inside the cabinet, identify the vinyl tubing assembly fitted with 5 numbered screwthread connectors. Referring to fig. 5 make the following connections to the assembled condenser:-
Connect No. 2 to lower water inlet.
Connect No. 4 to upper water outlet.
- 7 Ensure that the sealing o-ring and stabilising o-ring are correctly positioned, as shown in Figure 3a. Position the second condenser WC48/M2 onto the right hand vapour tube of the boiler with the distillate outlet tube facing the front and make the following tube connections:-

- 9 Pass the free end of the vinyl tubing through
 - i) the cabinet base, item 25, if the A8000 is to be wall mounted.
 - ii) the cabinet side, item 19, if bench mounted.
- 10 Take the 1000mm length of 16mm tubing and push through the larger of the three holes, item 21, on the side of the cabinet. This may be easier if the tubing is lubricated by wetting it with water. Continue until the tube extends approximately 250mm into the main chamber.

connection arm ensuring rubber seal is in position. Secure by screwing split nut into boiler plastic coupling.

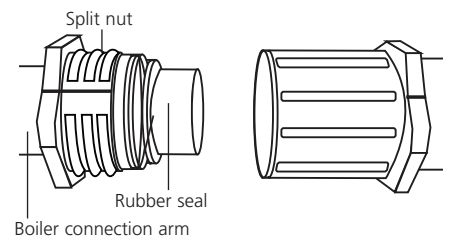

Figure 2b: Boiler coupling

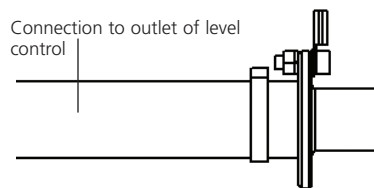

Figure 3b: Hose assembly 1

- Connect No. 1 to lower water inlet.
Connect No. 3 to upper water outlet.
- 8 From the bag of hoses, take the 1000mm length of 8mm diameter vinyl tubing fitted with a 'T' piece.
Connect the 180mm length of tubing from the 'T' piece to the distillate outlet of the condenser on the left-hand side. Secure with a tie strap and trim off excess strap length. Connect the 100mm length of tubing from the 'T' piece to the distillate outlet of the condenser on the right-hand side. Secure with a tie strap.

- 10b Refer to fig. 3b. Connect the 16mm tubing to the earthed spigot of hose assembly 1 and secure with a tie-trap.
- 11 Connect the open end of the 16mm tubing of hose assembly 1 to the outlet of the level control WL48 and secure with a tie strap.
Ensure that the Rotaflo PTFE stopcock of the WL48 is closed.

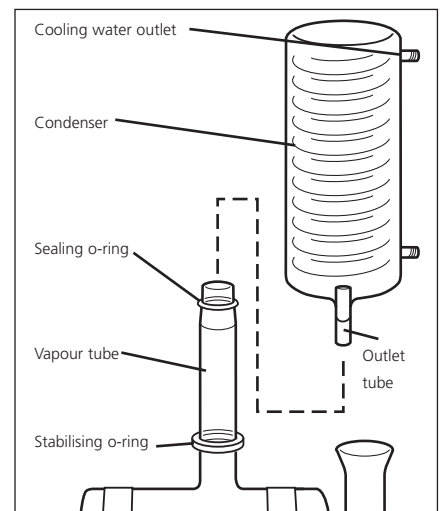

Figure 3a

— Blue - neutral
 — Brown - live
 — Earth - yellow/green

- 12 Refer to fig. 2b. Undo outer nut from plastic coupling. Open split plastic nut and place on outlet of boiler connection arm. Attach level control to boiler

- 13 Unscrew the black plastic screwcap from the WL48 and assemble the glass funnel WF48 – item 4.
- 14 Identify the tubing connection No. 5 and make the final connection to the boiler level control WL48, see fig. 5.
- 15 Take the 1000mm length of 8mm diameter tubing and push through the middle of the three holes item 20 on the side of the cabinet this may be easier if the tubing is lubricated by wetting it with water.
- 16 Unscrew the two black plastic screwcaps, and rubber rings, from the boiler. Slide both onto the heating elements, W48H, item 28. Insert the heaters into the boiler ensuring that the ends are supported in the glass nodules of the boiler.

Do not over-tighten the screwcaps as this may cause the boiler to break or push the heaters in too far as this may break the nodule.

- 17 Pass the electric cables of the heaters up into the electrical control compartment via the available orifices (refer to figure 4). Push the spade terminals onto the correct pins of the connecting strip (refer to figure 6).
- 18 Refit the cabinet end panel with all six screws and washers and the cabinet roof with all six countersunk screws. Replace the perspex viewing screen.

You have now assembled your Aquatron Water Still. Move the assembled A8000 to its working location – using the mounting bracket, item 7 if the unit is to be wall mounted. Ensure there is a space of at least 500mm to the right of the unit to allow access to the heating elements.

- 19 Connect the cold water supply to connection 18 fig. 4. Note the tubing selected should have a safe working pressure of at least equal to the pressure of the water supply and should be adequately secured by hose clips.

DO NOT TURN ON WATER SUPPLY.

20 Electrical Installation

 **THIS EQUIPMENT MUST BE EARTHED!**

The electrical installation should only be carried out by a qualified electrician.

The A8000 is classed as permanently connected equipment.

The earthed spigots should pass a high current (i.e. >200mA) earth continuity test.

The equipment is supplied with 1.5m of flexible, triple core, circular cable to the following specification:- 4.0mm², to BS 6500 or equivalent and <HAR> or BASEC approved.

Connection to the mains electrical supply, should be via a double pole 30mA RCD isolation breaker switch with a continuous current carrying capacity of 30A at 250v. and overcurrent protection of 30A.

Connection to the mains electrical supply, should be via a double pole isolation switch with a continuous current carrying capacity of 30A at 250v and overcurrent protection should be provided by a double pole approved fuse rated at 30A.

These devices should be sited near to the equipment and clearly marked – “Disconnect device for Aquatron Water Still”

The colour code for the mains cable is:-

Brown	– Live
Blue	– Neutral
Yellow/Green	– Earth

Mains Cable Replacement

If the mains cable requires replacement, only specially prepared spare mains lead obtained from Bibby Scientific should be used.

DO NOT SWITCH ON ELECTRICITY SUPPLY.

- 21 Connect the reservoir level control I/D4000/WLS as detailed on page 14 of the manual.

- 22 Refer to page 9 for operating instructions.

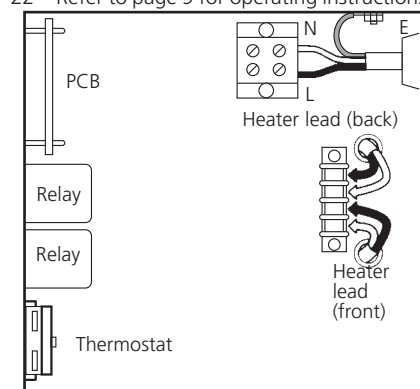





Fig 6 Terminations for A8000

	Blue - neutral
	Brown - live
	Earth - yellow/green

Replacing earthed hose assemblies

1. For hose assembly 1 follow the fitting instructions from 10 to 11.
2. Ensure that the earth wire is connected correctly to the earth post - see figs 4 and 10a.
3. For hose assembly 3 connect the 8mm tubing from the spigot to the water flow control switch and secure with a tie-strap. Connect the free end to the mains water inlet valve and secure with tie-straps. See figs. 5 and 10b.
4. Ensure that the earth wire is connected to the earth post - see figs. 4 and 10a.
5. Refer to fig. 5 and 10c. For hose assembly 4 connect the shorter 8mm vinyl tube to the junction where hose's 4 and 5 meet. Feed the free end of the 8mm tube through exit labelled 20, Fig. 4.
6. Ensure that the earth wire is connected to the earth post - see figs. 4 and 10a.

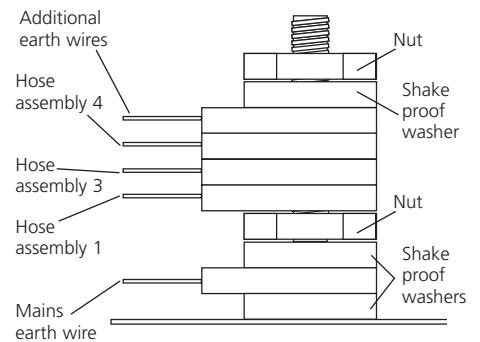

Figure 10a Earth post connection

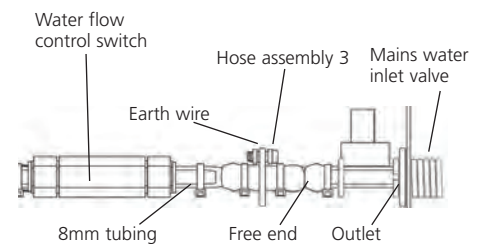

Figure 10b Hose assembly 3

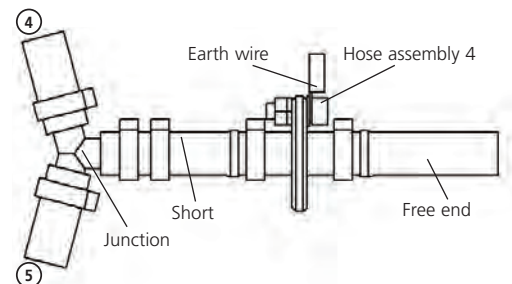

Figure 10c Hose assembly 4

A8000 Operation

The following instructions apply to the A8000 Aquatron water still where the water feed to the boiler is via the mains supply, or a header tank.

If the boiler is to be fed with either de-ionised or pre-treated water, please follow the instructions on page 15.

- 1 Before switching on either the mains electricity or water supply, identify the control switches and indicator lights on the front of the cabinet.

Green Light

When illuminated this shows that there is mains supply voltage to the unit. Under no circumstances should the cabinet end-panel be removed when this light is illuminated.

White "On Off" Switch

This is the primary switch for controlling water and electricity inside the still. The switch illuminates when pressed in the ON position.

Amber Light

When illuminated, this indicates that the distillate collection reservoir is full as detected by the level control.

White "Clean" Switch

This shuts off the heating element but allows water to flow into the boiler when the still is being commissioned or cleaned. When pressed in the CLEAN position the switch illuminates.

- 2 Carefully check the following:-
 - the appropriate electricity, water and drain services have been provided. If in doubt, consult the LOCATION & SERVICES section on page 1.
 - the ON/OFF switch on the control panel is in the OFF position.
 - the CLEAN switch is pressed in the CLEAN position.
 - the Rotafllo stopcock on the boiler level control WL48 is closed.
 - the Reservoir pressure switch is fitted to the distillate collection vessel.
 - the dummy shorting plug is fitted to socket item 8, fig. 4.

Ensure the earthed pipe kit is assembled correctly and the provided earth strap is securely fastened to the main case at the correct earth point. Check all glassware for any damage, such as chips, breaks or cracks.

- 3 Switch on the electricity supply – the green indicator light will illuminate.

- 4 Press the ON/OFF switch to the ON position – the switch will illuminate.

- 5 Recheck that the CLEAN switch is in the CLEAN position and illuminated.

- 6 Turn on the mains water supply and using the needle valve item 18, fig. 4, on the side of the cabinet, adjust the flow rate to approximately 2 litres/min.

Check that there are no water leaks from the hose connections.

- 7 Observe that the boiler is now filling with water to cover the heating elements. When the water has reached the pre-set level, the excess will be discharged to drain. Check that the drain water flows freely and does not "back-up" into the level control.

- 8 Switch the CLEAN button off by pressing it for a second time – the switch light goes out.

The heaters will start to warm up and eventually run at a red glow. If the flow rate is insufficient, the heaters will not switch on – this will require the needle valve to be opened further. After about 2 to 3 mins. of operation distilled water will emerge from the outlet pipe, falling into the collection reservoir.

- 9 To avoid excessive wastage of coolant water, make further adjustments to the needle valve. Slowly reduce the flowrate until the flow control switch, item 15, switches off the heaters – then increase the flow until the power is restored.

- 10 Refit the perspex viewing screen.

11 Safety Cut-Outs

All Aquatron water stills are protected by the following safety devices.

Flow Control Switch (item 15)

monitors the flow of coolant water into the still and shuts off the heating elements, if the flow is insufficient.

Thermostat Cut-Out (item 23)

In normal operation the water within the glass will be at 100°C. In single fault conditions, i.e. in the event of water

supply failure, the content will increase to 110°C where upon a resettable thermostat will operate. Once switched, the thermostat has to be manually reset. This is achieved by unscrewing the black knob, fig. 4, item 24, located inside the cabinet and pressing the reset button.

Reservoir Control (fig. 11)

is positioned on the collection reservoir and switches off both the electricity and water supply when the reservoir is full of distilled water. The water supply is only shut off around 7 mins. after the reservoir is full to allow the heating element to cool.

It is recommended that the operation of the flow switch and reservoir control be checked on a regular basis.

a) Simulation of Mains Water Supply Failure

Turn off the mains water supply at the tap. This should switch off the heating element. Turning the tap on again will switch the heater on.

b) Simulation of Reservoir Full Condition

Lower the glass pressure bell WFB, fig. 11, into the distillate to a depth of 150mm. This will switch off the heating element immediately and the cooling water after 7 minutes. Raising the bell will cause both to be re-supplied.

12 Switching Off

Push the CLEAN switch to the ON position. Wait until the residual heat contained in the heating elements has dispersed and no boiling is evident. Turn off water supply. Push ON/OFF switch to OFF position. Isolate from mains electricity supply.

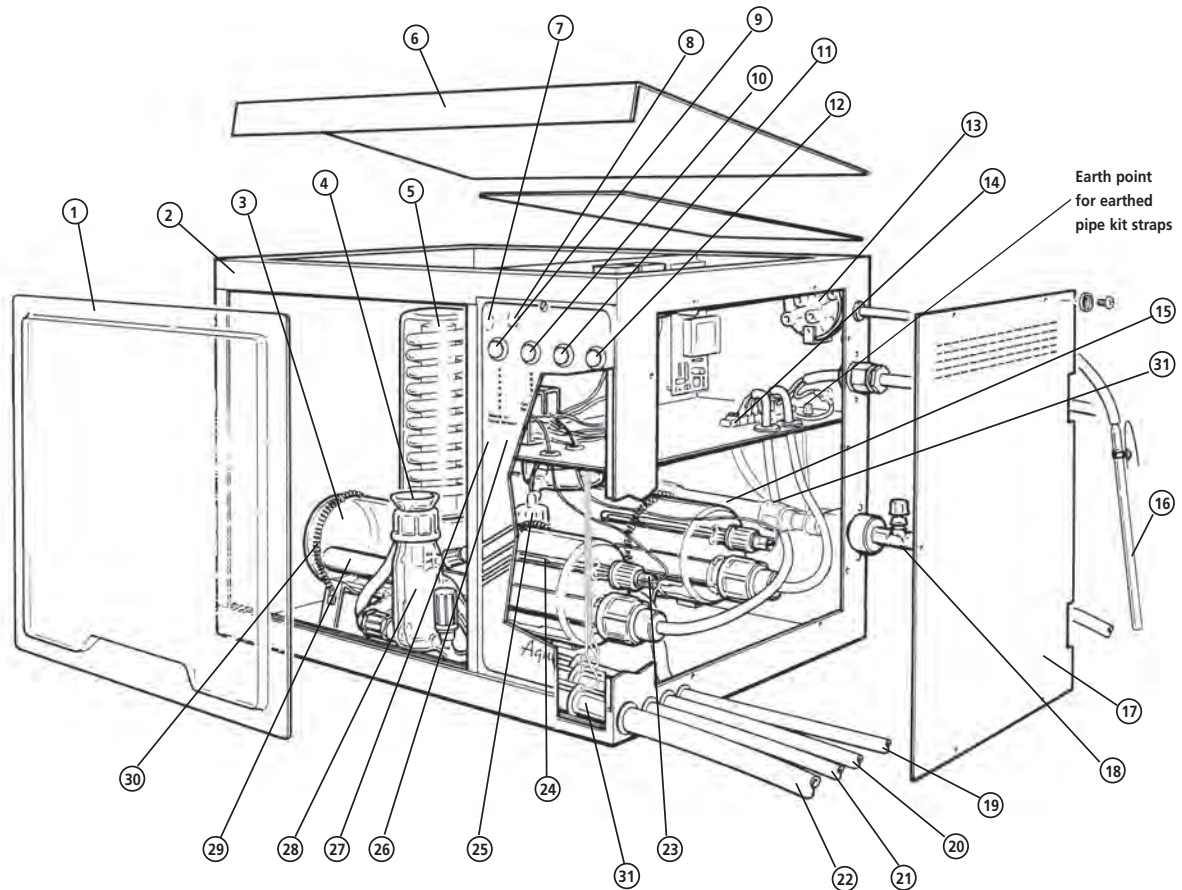

Fig 7: Major component parts A4000D

List of Major Components – A4000D

Item no.	Description	Catalogue number	Item no.	Description	Catalogue number
1	Perspex Screen	M484	16	Reservoir Level Control	I/D4000/WLS
2	Cabinet	M511	17	Cabinet End Plate	M511B
3	Boiler (2 off)	WB4	18	Mains Water Inlet with Needle Valve	7001059 (S)
4	Funnel	WF48	19	Distillate Outlet Pipe	–
5	Condenser (2 off)	WC48/M2	20	Drain Pipe from W4L2A	–
6	Cabinet Roof	M511A	21	Cooling Water Pipe to Drain (8mm)	–
7	Dummy Plug	–	22	Cooling Water Pipe to Drain (16mm)	–
8	Boiler Level Socket for W4L2A	–	23	Thermostat Glass Tube	WTT48
9	Green 'Mains On' Indicator	700691 (S)	24	Thermostat (2 off)	WT4
10	White 'On/Off' Switch	700988 (S)	25	Boiler Level Control (rear)	W4L2A
11	Amber 'Reservoir Full' Indicator	700987	26	Thermostat Re-set Button	WT4
12	White 'Clean' Switch	700988 (S)	27	Boiler Level Control (front)	WL48
13	Reservoir Pressure Switch	WPS	28	Boiler Plastic Coupling	WBC1
14	Terminal Strip for Heater Connection	700670(S)	29	Heating Element (2 off)	W48H
15	Water Flow Control Switch	I/A4000DHK/1	30	Boiler Retaining Springs	–
			31	Earthed pipe kit	A4000D/EK

A4000D Assembly

Your Aquatron A4000D has been designed with ease of assembly specifically in mind, but before commencing assembly please study the illustration, fig. 7 on page 10 to familiarise yourself with the general lay-out. During assembly, follow the sequence of instructions and do not connect the mains electricity supply until directed.

- 1 From the outer packaging remove all the components including the metal cabinet containing the glass boiler.

Item No.	Description	Cat. No.	Qty
5	Condenser	WC48/M2	2
29	Heater	W48H	2
27	Boiler Level Control (front)	WL48	1
25	Boiler Level Control (rear)	W4L2A	1
4	Funnel	WF48	1
16	Reservoir Level Control	I/D4000/WLS	1
-	Bag of plastic hoses & tie straps	WH48/3	1
31	Earthed pipe kits	A4000D/EK	1

- 2 Before unpacking the individual components, identify them on the check-list below.

- 3 Remove the perspex viewing screen, item 1 fig. 7 by using the finger recess to lift the screen out of the lower cabinet groove, then remove the internal packing which has protected the glass boilers during transit. Also sever the temporary ties holding the boiler retaining springs, item 30, in place.

- 4 Remove the cabinet end plate, item 17 by unscrewing the six retaining screws and 'shake proof washers'. Similarly, unscrew the six countersunk screws to remove the cabinet roof (item 6).

- 5 Withdraw the metal thermostat probe, fig. 7. item 24, from the glass tube inside the front boiler.

- 6 Remove the front boiler from the cabinet by releasing the retaining springs, item 30.

- 7 Ensure that the sealing o-ring and stabilising o-ring are correctly positioned, as shown in Figure 3a. Mount one of the condensers WC48/M2 onto the vapour tube of the rear boiler with the distillate outlet facing the front. See fig. 8a.

- 8 Select one of the 1000mm lengths of 8mm vinyl tubing and connect to the condenser distillate outlet tube of the rear condenser. Secure with tie strap. Pass the free end of the vinyl tubing through hole, item 19 in the cabinet side.

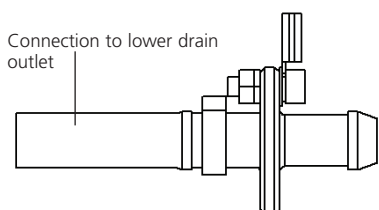
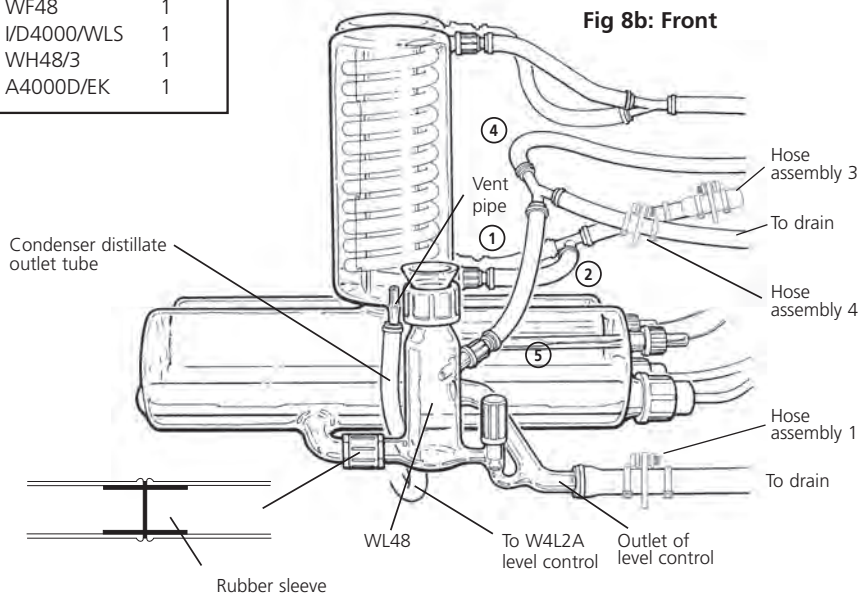
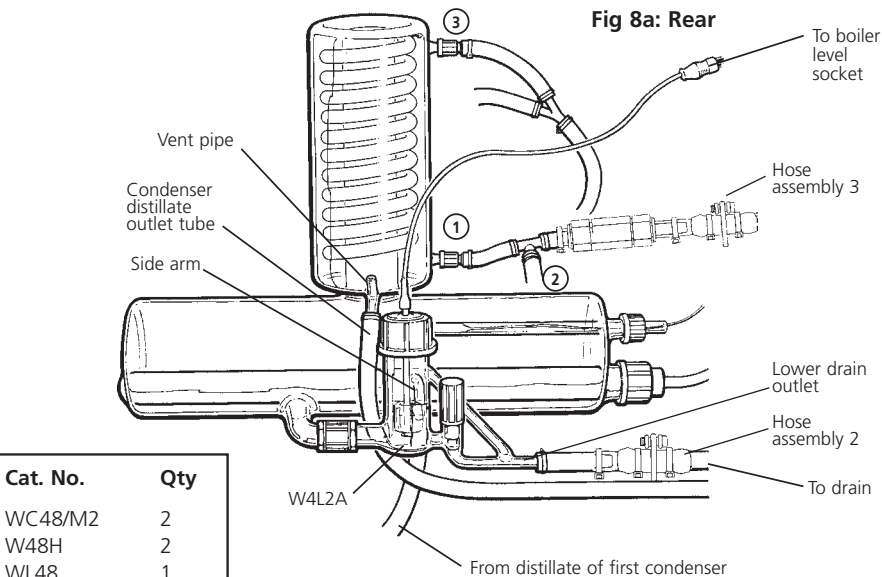

Figure 2a: Hose assembly 2



- 9 Refer to fig. 2a Take the Level Control, W4L2A, item 25. Connect the open end of the 8mm hose of hose assembly 2 to the lower drain outlet of the W4L2A and secure with tie strap.
- 9b From the hose pack take a 1000mm length of 8mm vinyl hose. Connect the 8mm hose to the earthed spigot of hose assembly 2 and secure with a tie strap. Feed the free end of the tubing through the opening item 20 in the side of the cabinet.
- 10 From the hose pack, take the 300mm length of vinyl tubing and connect to the side arm of the W4L2A, securing with a tie strap. Direct the free end of the tubing to the front of the cabinet.

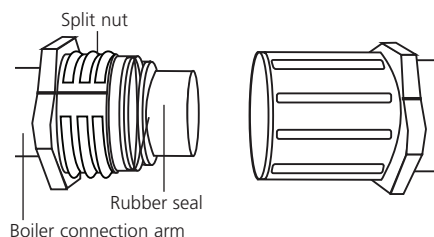

Figure 2b: Boiler coupling

- 11 Refer to fig. 2b. Undo outer nut from plastic coupling. Open split plastic nut and place on outlet of boiler connection arm. Attach level control W4L2A to boiler connection arm ensuring rubber seal, is in position. Secure by screwing split nut into boiler plastic coupling. Ensure that the Rotaflo Stopcock on the W4L2A is closed.
- 12 Connect the 4 pin DIN plug from the float switch of the W4L2A to the DIN socket, item 8, fig.7, situated inside the main chamber of the cabinet.
- 13 Refit the front boiler into the cabinet and secure with retaining springs.
- 14 Ensure that the sealing o-ring and stabilising o-ring are correctly positioned, as shown in Figure 3a. Fit the remaining condenser onto the boiler with the distillate outlet at the front. See fig. 8b.
- 15 Connect the free end of the 300mm vinyl tubing (instruction 10 refers) to the distillate outlet of the front condenser. Secure with a tie strap.
- 16 Refit the metal thermostat probe into glass tube of the boiler.

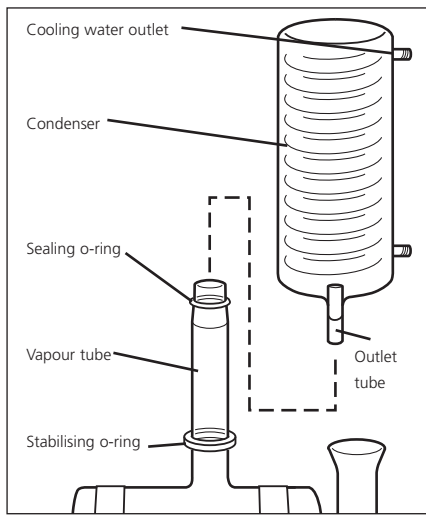

Fig 3a

	Blue - neutral
	Brown - live
	Earth - yellow/green

17 Take the 1000mm length of 16mm tubing and insert through the hole, item 22 in the cabinet side. The tubing should extend approximately 250mm into the cabinet, roughly level with the outlet of the condenser.

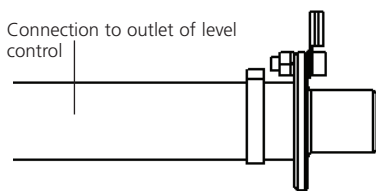

Figure 3b: Hose assembly 1

17b Refer to fig. 3b. Connect the 16mm tubing to the earthed spigot of hose assembly 1 and secure with a tie-strap.

18 Connect the open end of the 16mm tubing of hose assembly 1 to the outlet of the level control WL48 item 28 fig7. Secure with a tie strap. Ensure that the Rotaflo Stopcock of the WL48 is closed.

19 Undo outer nut from plastic coupling. Open split plastic nut and place on outlet of boiler connection arm. Attach level control W4L2A to boiler connection arm ensuring rubber seal is in position. Secure by screwing split nut into boiler plastic coupling. Ensure there are no stresses from the 16mm tubing on the connection.

20 Looking inside the cabinet, identify the vinyl tubing assembly fitted with 5 numbered screwthread connectors. Referring to illustration fig. 8a and 8b make the following connections:-

- Connector no. 1 to lower water inlet of rear condenser.
- Connector no. 2 to lower water inlet of front condenser.
- Connector no. 3 to upper water outlet of rear condenser.
- Connector no. 4 to upper water outlet of front condenser.
- Connector no. 5 to front boiler level control WL48.

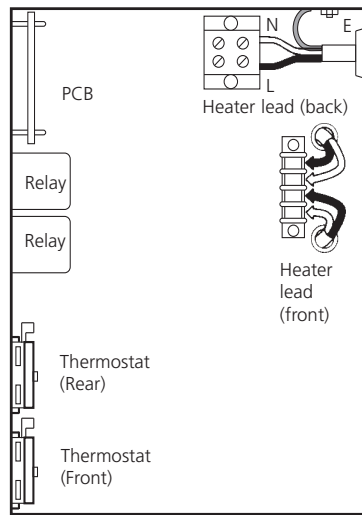

Fig 9

	Blue - neutral
	Brown - live
	Earth - yellow/green

21 The tubing assembly is also fitted with a 1 metre length of 8mm diameter vinyl tubing. Feed the free end of this tubing through the opening, item 21, in the side of the cabinet.

22 Unscrew the black plastic screwcap from the WL48 and assemble the glass funnel WF48 – item 4.

23 Unscrew the black plastic screwcap and rubber ring from the rear boiler. Slide both onto heating element W48H – item 29.

24 Assemble the heater into the boiler ensuring that the far end is supported in the glass nodule of the boiler.

Do not over-tighten the screwcaps as this may cause the boiler to break or push the heaters in too far as this may break the nodule.

25 Pass the electric cable of the heater up into the electrical control compartment via the orifice available. Push the spade terminals onto the CORRECT PINS of the connecting strip (refer to fig. 9).

26 Repeat the operation to fit the second heating element for the front boiler.

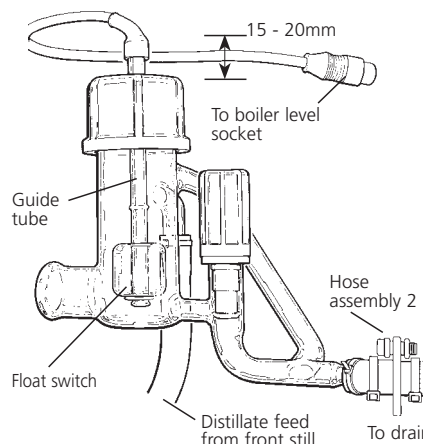

Fig 10 W4L2A Level Control

27 Refit the cabinet end panel with all six screws and washers. Refit cabinet roof

with the six countersunk screws.

28 Refit the perspex viewing panel.

29 Move assembled A4000D to desired working location. ensure there is a space of at least 500mm to the right of the unit to allow access to the heating elements.

30 Connect the cold water supply to connection 18 fig. 7.

Note: The tubing selected should have a safe working pressure at least equal to the pressure of the water supply. The tubing should be adequately secured by hose clips.

DO NOT SWITCH ON.

31 Electrical Installation

THIS EQUIPMENT MUST BE EARTHED!

The electrical installation should only be carried out by a qualified electrician.

The A4000D is classed as permanently connected equipment.

The earthed spigots should pass a high current (i.e. >200mA) earth continuity test.

The equipment is supplied with 1.5m of flexible, triple core, circular cable to the following specification:- 4.0mm², to BS 6500 or equivalent and <HAR> or BASEC approved.

Connection to the mains electrical supply, should be via a double pole 30mA RD isolation breaker switch with a continuous current carrying capacity of 30A at 250V and overcurrent protection of 30A.

These devices should be sited near to the equipment and clearly marked – “Disconnect device for Aquatron Water Still”

The colour code for the mains cable is:-

- Brown – Live
- Blue – Neutral
- Yellow/Green – Earth

Mains Cable Replacement

If the mains cable requires replacement, only specially prepared spare mains lead obtained from Bibby Scientific should be used.

DO NOT SWITCH ON ELECTRICITY SUPPLY.

32 Connect the reservoir level control I/D4000/WLS as detailed on page 14 of the manual.

33 Refer to page 13 for operating instructions.

Replacing earthed hose assemblies

1. For hose assembly 1 follow the fitting instructions from 17 to 18.
2. Ensure that the earth wire is connected correctly to the earth post - see figs 7 and 10a.
3. For hose assembly 2 follow the fitting instructions from 9 to 9b.
4. Ensure that the earth wire is connected to the earth post - see figs. 7 and 10a.
5. For hose assembly 3 connect the 8mm tubing from the spigot to the water flow control switch and secure with a tie-strap. Connect the free end to the mains water inlet valve and secure with tie-straps. See figs. 8a and 10b.
6. Ensure that the earth wire is connected to the earth post - see figs. 7 and 10a.
7. Refer to fig. 8b and 10c. For hose assembly 4 connect the shorter 8mm vinyl tube to the junction where hose's 4 and 5 meet. Feed the free end of the 8mm tube through exit labelled 21, Fig. 7

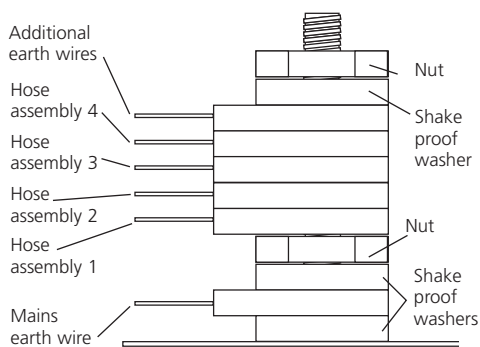

Figure 10a Earth post connection

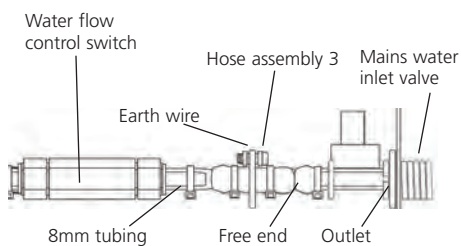

Figure 10b Hose assembly 3

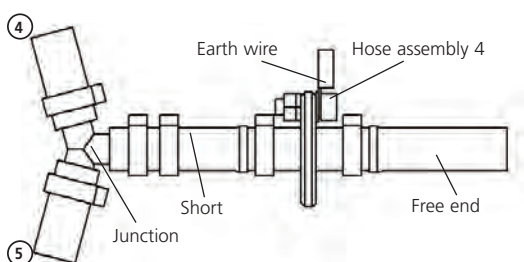

Figure 10c Hose assembly 4

A4000D Operation

The following instructions apply to the A4000D double distillation stills where the water feed to the first stage boiler is either via the mains supply or a header tank.

If it is desired to feed the first stage boiler with deionised or pre-treated water to obviate cleaning, then the instructions on page 15 should be followed.

- 1 Before switching ON either mains electricity or water supply, identify the control switches and indicator lights on the front of the cabinet.

Green Light

When illuminated this shows there is mains supply voltage within the unit. In no circumstances should the cabinet end-panel be removed when this light is illuminated.

White "On/Off" Switch

The primary switch for controlling water and electricity inside the still. The switch illuminates when pressed in the ON position.

Amber Light

When illuminated, this indicates that the distillate collection reservoir is full, as detected by the level control.

White "Clean" Switch

This shuts off the heating elements but allows water to flow into the boiler. Used for filling the boiler on commissioning and cleaning purposes. The switch illuminates when pressed in the 'ON' position.

- 2 Carefully check the following:-
 - That the appropriate electricity, water and drain services have been provided. If in doubt,- consult the "Location and Services" notes on page 1.
 - Water still ON/OFF switch is in the OFF position.
 - i.e. - switch should not be pressed and should not illuminate.
 - Water still CLEAN switch is in the ON position.
 - The Rotaflo stopcock on the front boiler level control WL48 is closed.
 - The float switch on the second stage boiler level control W4L2A is set at the factory. However, check that this has not been disturbed during transit. A rough check is that the distance from the top of the large screw cap of the W4L2A to the top of the glass guide tube should be approximately 15-20mm see fig. 10.
 - The dummy shorting plug is fitted to socket item 7, fig. 7.

Ensure the earthed pipe kit is assembled correctly and the provided earth strap is securely bonded to the main case at the correct earth point.

Check all glassware for any damage, such as chips, breaks or cracks.

- 3 Switch on the electricity supply. (**Note:** the green indicator light will illuminate).
- 4 Press the ON/OFF switch to the ON position (switch will illuminate).
- 5 Re-check that the Clean switch is in the 'ON' position (switch will illuminate).
- 6 Turn on the mains water supply and using the needle valve, item 18, fig. 7, on the side of the cabinet, adjust the flow rate to approximately 2 litres/minute.

Check there are no water leaks from the hose connectors.
- 7 Observe that the front boiler is now filling with water to cover the heating elements. When the water has reached the pre-set level excess will be discharged to drain. Check that the drain water flows freely and does not "back-up" into the level control.

- 8 Press the Clean button to 'OFF' position. (Switch light should go out).

The heater on the front boiler should start to warm up and eventually run with a red glow. After a short time distilled water will emerge from the outlet pipe item. This should feed into the empty rear boiler via the level control W4L2A.

- 9 Allow the rear boiler to fill with single distilled water (for approx. 20 to 30 minutes), keeping an eye on the level. Note that the heater of the second stage only comes on when the level of single distilled water in the rear boiler is at about the equator. It may be necessary to adjust the level of the float switch of the WL42A to achieve this condition. Refer to fig. 10.

Lifting the guide tube increases the level at which the heating element will switch on.

Lowering the guide tube decreases the level at which the element will switch on.

Double distilled water ultimately flows from outlet pipe, item 19. This should fall away from the still with no kinks, restrictions or U bends.

- 10 To avoid excessive wastage of coolant water, make further adjustments to the needle valve, item 18. Slowly reduce the flowrate until the flow control, item 15, switches off the heaters - then increase the flow until the power is restored.

11 Safety Cut-Outs

All Aquatron water stills are protected by the following safety devices.

Flow Control Switch (item 15)

monitors the flow of coolant water into

the still and shuts off the heating elements, if the flow is insufficient.

Thermostat Cut-Out (item 24)

In normal operation the water within the glass will be at 100°C. In single fault conditions, i.e. in the event of water supply failure, the content will increase to 110°C where upon a resettable thermostat will operate. Once switched, the thermostat has to be manually reset. This is achieved by unscrewing the black knob, fig. 7, item 26, located inside the cabinet and pressing the reset button.

Reservoir Control (fig. 11)

is positioned on the collection reservoir and switches off both the electricity and water supply when the reservoir is full of distilled water. The water supply is only shut off around 7 mins. after the reservoir is full to allow the heating elements to cool.

It is recommended that the operation of the flow switch and reservoir control be checked on a regular basis.

a) Simulation of Mains Water Supply Failure

Turn off the mains water supply at the tap. This should switch off the heating element. Turning the tap on again will switch the heaters on.

b) Simulation of Reservoir Full Condition

Lower the glass pressure bell WFB, fig. 11, into the distillate to a depth of 150mm. This will switch off the heating element immediately and the cooling water after 7 minutes. Raising the bell will cause both to be re-supplied.

12 Switching Off

Push the CLEAN switch to the ON position. Wait until the residual heat contained in the heating elements has dispersed and no boiling is evident. Turn off water supply. Push ON/OFF switch to OFF position. Isolate from mains electricity supply.

Distillate Collection A4000, A8000, A4000D

Each Aquatron water still is supplied with a RESERVOIR LEVEL CONTROL, I/D4000/WLS, fig. 11. This automatically switches off the heating elements and coolant water supply when the distillate collection reservoir is filled with distilled water.

Note that, the control is fitted with a 'delay timer' which switches off the coolant water supply approximately 7 minutes after the heating elements. This is to allow time for the heaters to cool and for boiling to cease.

The control also automatically switches on the heating elements and coolant water supply when the level of distillate in the collection reservoir falls.

It is possible to fit the glass pressure bell of the control to most types of reservoir and container by means of a metal clip WFC/1 which is provided.

Alternatively, Bibby Scientific offer a purpose designed reservoir collection system WR20 fitted with a special adapter to hold the bell, see fig. 12.

Fitting the Reservoir Control I/D4000/WLS to Collection Vessels

- 1 Position the distillate collection reservoir in a suitable location. This should be below the water still so that the vinyl rubber tubing transporting the distilled water from the still can fall down to the reservoir without restrictions, kinks or U bends.
- 2 Take the Reservoir Level Control I/D4000/WLS and connect the free end of the rubber tubing to the nozzle, item 13, of the reservoir pressure switch located on the side of the cabinet.
- 3 Use the metal clip to fit the glass pressure bell inside the distillate collection reservoir. Refer to fig. 11.
- 4 Position the bell so that the open end is 140mm below the desired distillate level.

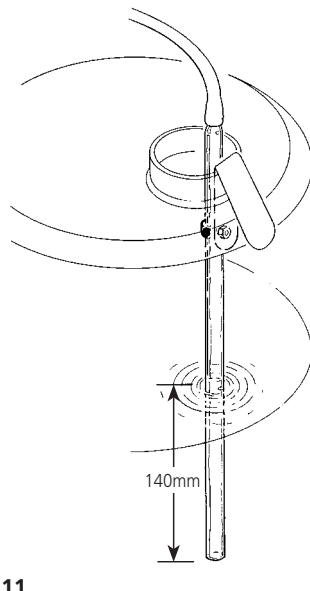

Fig 11
I/D4000/WLS Reservoir level control

Reservoir System WR20 & WS20

Bibby Scientific offer a purpose designed reservoir system for the collection of distilled water from your Aquatron.

This comprises:-

- WR20 – 20 litre Pyrex glass reservoir complete with Rotaflo stop-cock and special lid.
- WS20 – Reservoir stand, 43cm high for use with WR20.

The lid of the reservoir has a side arm for connection to the distillate feed from the Aquatron and a vent fitted with a bacteriological filter to maintain the purity of the water. A screwthread fitting is also provided to support the Reservoir Level Control I/D4000/WLS.

Location & Assembly

- 1 Locate the reservoir in a position which is below the level of the water still.
- 2 Fit the Rotaflo drain cock to the lower ground glass socket of the reservoir and secure with the plastic joint clip.

- 3 Take the bacteriological filter and connect this to the top of the glass feed-pipe using the vinyl tubing provided. Fit the feed pipe and filter into the reservoir lid via the large screwcap fitting.
- 4 Fit the Reservoir Level Control I/D4000/WLS to the lid via the small screwcap fitting. Note that the stem of the glass pressure bell should extend approximately 50mm above the screwcap (see illustration).
- 5 Place the assembled lid into the socket of the reservoir.
- 6 Take the rubber tubing from the reservoir level control I/D4000/WLS and connect to the small plastic nozzle, item 13, on the side of the water still cabinet.
- 7 Take the vinyl plastic tubing from the distillate outlet of the water still and connect to the side-arm of the feed pipe on the reservoir lid. Ensure that the tubing falls down to the reservoir without any restrictions, kinks or U bends.

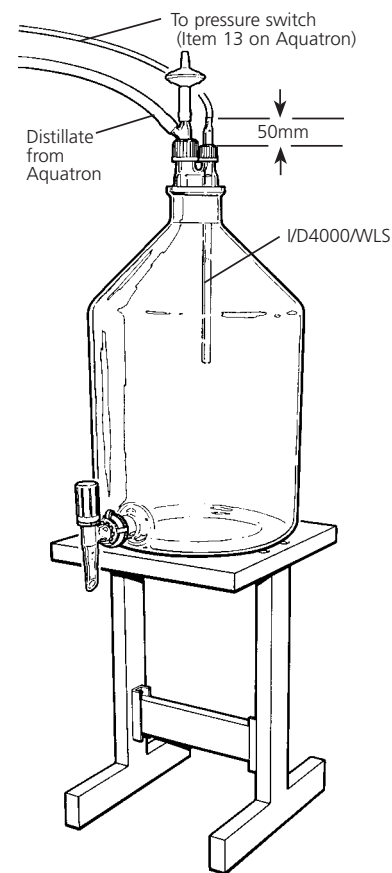

Fig 12
Reservoir WR20 and Stand WS20

Connection of Aquatron stills to deionised and pre-treated water supplies

Many laboratories prefer to feed their water stills with deionised or pre-treated water to obviate the need for boiler cleaning and de-scaling.

Your new Aquatron can be easily converted to deionised water-feed by use of a simple accessory – the WATER FEED CONVERSION KIT, Catalogue No. WCK/N. This kit permits the still to operate with most types of deioniser and also piped supplies of pre-treated water. Please contact Bibby Scientific or your laboratory trade house for ordering and price information.

The sequence of operations to fit the WCK/N is detailed below:-

- 1 Assemble the Aquatron as described under the relevant ASSEMBLY instructions.
A4000 refer to page 3
A8000 refer to page 7
A4000D refer to page 11
- 2 Ensure the unit is isolated from the mains electricity supply.
- 3 Remove the perspex viewing screen, the cabinet end-panel and the cabinet roof.
- 4 Lift out the front switch panel from the cabinet groove by unscrewing the counter sunk screw at the top of the panel. This will allow better access to the plumbing system.
- 5 Identify the length of 8mm vinyl tubing which connects the side arm of the Boiler Level Control WL48 and the outlet of the Water Flow Control Switch (WS48/1 or WS48/2). Remove the tubing by unscrewing the plastic screwthread connector from the WL48 and then severing the tie strap on the Flow Switch.
- 6 From the Water Feed Conversion Kit WCK/N, take the 1000mm length of 8mm vinyl tubing. Push one end of the tubing onto the OUTLET of the Water Flow Control Switch, and secure with a tie-strap.
- 7 Push the free end of the tubing through the vacant orifice in the side of the cabinet and lead to the drain.
- 8 Take the 220mm length of reinforced plastic tubing with earthed spigot (I/WCK02) from the WCK/N kit. Connect the free-end to the nozzle of the solenoid valve, item 1, fig 13. Secure with metal hose clip. Fit the other end of the tubing to the side arm of the Level Control WL48, item 3, using the screwthread connector.

- 9 Refit the front switch panel and secure with screw.
- 10 Take the plastic screwcap, hose connector and rubber ring from the WCK/N kit. Fit to the deionised water inlet, item 2, fig. 13, having first removed the red protective cap.
- 11 Unscrew the screwcap, item 4, fig. 13, from the Level Control WL48. Remove the glass funnel WF48 and the rubber ring which are no longer required.
- 12 Take the glass float, guide tube and washer assembly, item 5, and pass the electric lead and plug through the hole in the screwcap. Carefully push the washer into the cap.
- 13 Refit the screwcap and float assembly to the Level Control WL48 ensuring that the end of the guide tube locates in the well at the base.
- 14 Remove the dummy shorting plug from the socket item, 6, fig. 13, and fit the plug from the Float Switch.
- 15 Replace the cabinet end-plate and roof.
- 16 Connect the hose connector, item 2, of the deionised water inlet to the outlet of the deioniser or pre-treated water supply. Note the tubing selected should have a safe working pressure of at least equal to the pressure of the water supply and should be adequately secured with hose clips.

Operation

- 1 Before switching on either the mains electricity or water supply, identify the control switches and indicator lights on the front of the cabinet.

Green Light

When illuminated this shows that there is mains supply voltage to the unit. Under no circumstances should the cabinet end-panel be removed this light is illuminated.

White 'ON/Off' Switch

This is the primary switch for controlling water and electricity inside the still. The switch illuminates when pressed in the ON position.

Amber Light

When illuminated this indicates that the distillate collection reservoir is full as detected by the level control.

White 'Clean' Switch

This shuts off the heating element but allows water to flow into the boiler when the still is being commissioned or cleaned. When pressed in the CLEAN position the switch illuminates.

- 2 Carefully check the following:-
 - the appropriate electricity, water and drain services have been provided. If in doubt, consult the LOCATION AND SERVICES section on page 1.
 - the ON/OFF switch on the control panel is in the OFF position.
 - the CLEAN switch is pressed in the CLEAN position.
 - the Rotaflo Stopcock on the boiler level control WL48 is closed.
 - the Reservoir pressure switch is fitted to the distillate collection vessel.
 - the dummy shorting plug has been removed from it's socket and replaced with the lead from the WCK/N.

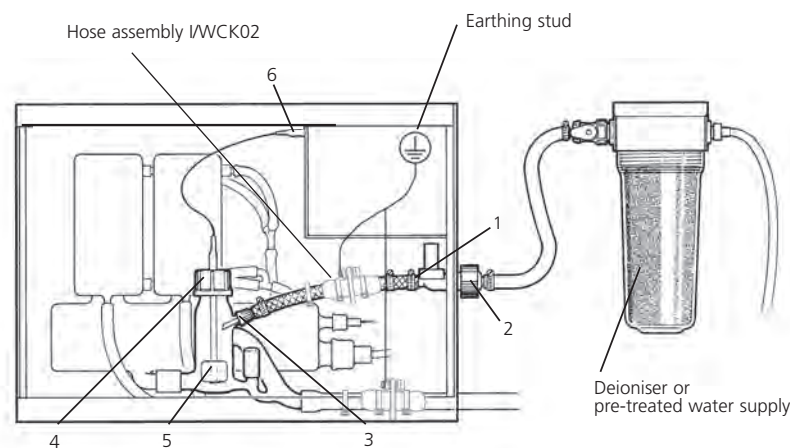

Fig 13 Conversion to deionised or pre-treated water supply

- 3 Switch on the electricity supply – the green indicator light will illuminate.
- 4 Press the ON/OFF switch to the ON position – the switch will illuminate.
- 5 Recheck that the CLEAN switch is in the CLEAN position and illuminated.
- 6 Turn on the mains water supply and using the needle valve on the side of the cabinet, adjust the flow rate to approximately 1 Litre/Min. for A4000 and 2 Litres/Min. for A8000 and A4000D. Ensure that the mains water flows to drain without any restriction.
- 7 Turn on the supply of deionised or pre-treated water. Observe that deionised water enters the boiler via the float system of the WCK/N.
- 8 Allow deionised water to flow into the boiler until the heating element(s) is covered by approximately 10mm. At this level the flow of deionised water into the boiler should be automatically cut off by the WCK/N float system.
- 9 Switch off the CLEAN button by pressing it for a second time – the switch light goes out.

The heater(s) will start to warm up and eventually run at a red glow. (If heater fails to glow, check that the flow of mains water is adequate).
- 10 Allow distillation to commence and observe that the WCK/N float system allows fresh deionised water to enter the boiler and maintain a satisfactory operating level.

If the deionised supply fails then the WCK/N will switch off the heater until it is restored.
- 11 Replace the perspex viewing screen.

Cleaning A4000, A8000, A4000D

When any of the Aquatron stills have been used to produce distilled water directly from a mains water supply, there will inevitably be a build-up of scale in the boiler and on the heating element(s). To obtain optimum performance from the still the scale should be removed on a regular basis. The time span between cleaning depends entirely upon the hardness of the water supply. In very hard water areas it may be necessary to clean the still once a week, whereas in soft water areas several weeks may elapse before cleaning is necessary.

It should not, of course, be necessary to de-scale the second stage boiler on the A4000D or when the stills have been operated from a de-ioniser.

Cleaning the still involves the use of 10% formic acid or kettle descaler. As a safety precaution protective clothing, gloves, mask and goggles should be worn during cleaning.

Note:

The cabinet and perspex screen should be cleaned using a dilute detergent solution only.

It is possible to descale the Aquatron Water Still without dismantling the glassware by following these instructions in conjunction with Control of Substances Hazardous to Health regulations (COSHH) 1988.

Method

- 1 Push the CLEAN switch to the CLEAN position – the switch illuminates.
- 2 Observe that the heating element/s has switched off. Allow boiling to stop and water to cool.
- 3 Push ON/OFF switch to OFF position.
- 4 Remove perspex screen.
- 5 Open the Rotaflo stopcock on the level control WL48, allow the boiler to empty to $\frac{3}{4}$'s of its full capacity, and close stopcock.
- 6 Carefully add about 100ml 10% formic acid solution or kettle descaler into the glass funnel of the WL48.
- 7 Push the ON/OFF switch to the ON position, the boiler will refill to its operating level.
- 8 Push the ON/OFF switch to the OFF position.

- 9 Allow the chemical reaction within the boiler to continue until all the deposits have been removed.

Note – if scale has built up above the operating level, the boiler may be completely filled by either lifting the drain pipe or restricting the flow of water to drain. This operation must be carefully controlled so that the boiler does not over-fill and cause water to be forced over the funnel top.

- 10 Open Rotaflo stopcock and allow contents of the boiler to drain completely.

Note:

If the acid added to the boiler has not been completely neutralised, the liquid flowing to drain may be strongly acid. Necessary safety precautions should be observed around the drain position, and any effluent control procedures followed.

- 11 Close Rotaflo stopcock.
- 12 Push ON/OFF switch to ON position and allow boiler to fill with water. Again the boiler may be completely filled by following procedure detailed in step 8.
- 13 Push ON/OFF switch to OFF position.
- 14 Drain the boiler by opening the Rotaflo stopcock.
- 15 Repeat steps 11-14 two or three times until the boiler has been thoroughly flushed through.
- 16 The still is re-started by finishing the cleaning cycle at step 12, and then pushing the CLEAN switch to the OFF position. (Switch is not illuminated).

Before collecting the distillate the still should be allowed to run for about 10 minutes with the distillate running to drain, this will ensure that any residual acid is removed.

Note:

The amount of acid required will depend upon the degree of scaling. If after performing the cleaning cycle deposits are left in the boiler, it may be necessary to repeat the cleaning cycle using a fresh quantity of acid.

The benefits gained from regular cleaning cannot be over emphasised.

Fault Finding

A4000, A8000, A4000D

In the event of operating difficulties with your Aquatron it is suggested that the following basic checks are made. **(Please note that these checks should only be carried out by suitably qualified personnel).**

If these checks fail to identify and remedy the problem then you are advised to seek the help of your supplier or the Technical Services Department of Bibby Scientific Ltd.

1 Unit completely inoperative – No mains green indicator light on

Check the electricity supply to the Aquatron and ensure that a fuse has not blown at the plug or supply fuse board. (This check should be conducted by a QUALIFIED ELECTRICIAN).

2 Heater(s) not on – Mains green indicator light on water flowing

a) Check the Aquatron switches are in the correct mode, i.e.:

ON/OFF switch is in the ON position.

CLEAN switch is in the OFF position.

Check that the Reservoir indicator light is NOT illuminated and indicating a full collection reservoir.

b) Check that the 15 amp fuses, located inside the electrical chamber of the cabinet, have not blown. (This check should be conducted by a QUALIFIED ELECTRICIAN).

c) Check that the flow of cooling water is sufficient.

A4000 requires a flowrate of at least 1 litre/min.

A8000, A4000D requires a flowrate of at least 2 litres/min.

If the flowrate is NOT sufficient then:-

Check the mains water supply is turned on.

Check the needle valve on the right-hand side of the cabinet is open.

Check the water inlet filter is not blocked (see note 8).

Check the flow of water is not impeded by blockages or restrictions.

3 Heater(s) not on – Water not flowing Mains green indicator light on

Check that the thermostat has not operated. Confirm this by pressing the thermostat reset button located inside

the main chamber of the cabinet.

If the thermostat has cut-out then the cause should be identified at once.

Check that the boiler contains sufficient water.

Check that the plumbing connections are not leaking.

Check that the stopcock on the boiler level control WL48 is closed.

4 Heater in second stage boiler of A4000D not on

Check the setting of the boiler level control W4L2A. See page 12 for details.

Check thermostat has not operated. See notes under 3.

5 Water level in boiler too high – Choking of condenser

Check that the flow of water into the boiler is not excessive. Control flow by adjusting needle valve on right-hand side of cabinet.

Check that the coolant water drain pipe falls away from the Aquatron without restrictions or U bends.

If level of water in the second stage boiler of model A4000D is too high, then:-

Check setting of the float switch in boiler level control W4L2A. See page 12 for details.

6 Distillate quality low –

Check the condition of the boiler and clean if heavily scaled.

7 Distillate collection reservoir floods –

Check the location of the Reservoir level control I/D4000/WLS inside the reservoir. See page 13 for details.

Check that the I/D4000/WLS0 pipe connections between the glass bell and Aquatron are secure and air tight.

8 Cleaning blocked water filters

Your Aquatron is fitted with a built-in water filter to prevent the ingress of particulate matter into the plumbing system.

The filter can be examined and cleaned if necessary by unscrewing the black plastic screwcap which secures the needle valve, item 18, to the right-hand side of the cabinet.

A similar filter is also incorporated on the same side of the cabinet for use with pre-treated water supplies. Access is via the black screwcap which secures the hose nozzle.

9 Persistent tripping of the RCD

This is likely to be due to the integrity of the heater and should therefore be replaced.

Additional checks for Aquatrons fed with deionised or pre-treated water

a) Boiler does not fill –

Check that supply of pre-treated water is switched on.

Check input water filter on side of cabinet is not blocked (see note 8).

Check Water Feed Conversion Kit WCK/N is correctly fitted and adjusted. See page 14 for details.

b) Heater(s) not on –

Check water level in boiler is above the heating element.

Check Water Feed Conversion Kit WCK/N is correctly fitted and adjusted. See page 14 for details.

List of Spares

	Catalogue no.
Boiler for A4000, A4000D	WB4
Boiler for A8000	WB8
Boiler plastic coupling	WBC1
Boiler Level Control	WL48
Boiler level control for A4000D rear boiler	W4L2A
Float switch for W4L2A	I/B595264
Condenser	WC48/M2
Electric fuse, 15 amp, HRC	W15F
Funnel	WF48
Heater	W48H
Hose assembly for A4000	WH48/1
Hose assembly for A8000	WH48/2
Hose assembly for A4000D	WH48/3
Printed circuit board	WPCB/M3
O ring (lower) for vapour tube	QR38/24
O ring (upper) for vapour tube	WB48/01
Reservoir assembly complete	WR20
Components:–	
20 litre glass reservoir	1569/22
Bacteriological filter	WR20/01
Lid/adapter	WR20/02
Feed pipe	WR20/03
Stopcock	WR20/04
Stopcock retaining clip	KC29
Reservoir metal stand	WS20
Reservoir Level Control	I/D4000/WLS
Reservoir pressure switch	WPS
Rubber ring for heating element	QR38/24
Rubber ring for thermostat	QR18/10
Rubber rings for reservoir lid	QR18/10 & QR28/18
Screwcap for heating element	QC38/25
Screwcap for thermostat	QC18/11
Screwcaps for reservoir lid	QC18/11 & QC28/21
Screwthread connectors for hose assemblies	4510/02
Solenoid valve	WSVA
Thermostat for A4000 & A4000D	WT4
Thermostat for A8000	WT8
Thermostat glass tube	WTT48
Water Feed Conversion kit	WCK/N
Float switch for WCK/N	WCK/01N
Water Flow Control Switch for A4000	I/A4000HK/1
Water Flow Control Switch for A8000 & A4000D	I/A8000HK/1
Water flow control switch for A4000D	I/A4000HK/I
Earthed spigot kit for A4000	A4000/EK
Earthed spigot kit for A8000	A8000/EK
Earthed spigot kit for A4000D	A4000D/EK
Earthed pipe kit - Deioniser	I/WCK02

Circuit diagram for A4000

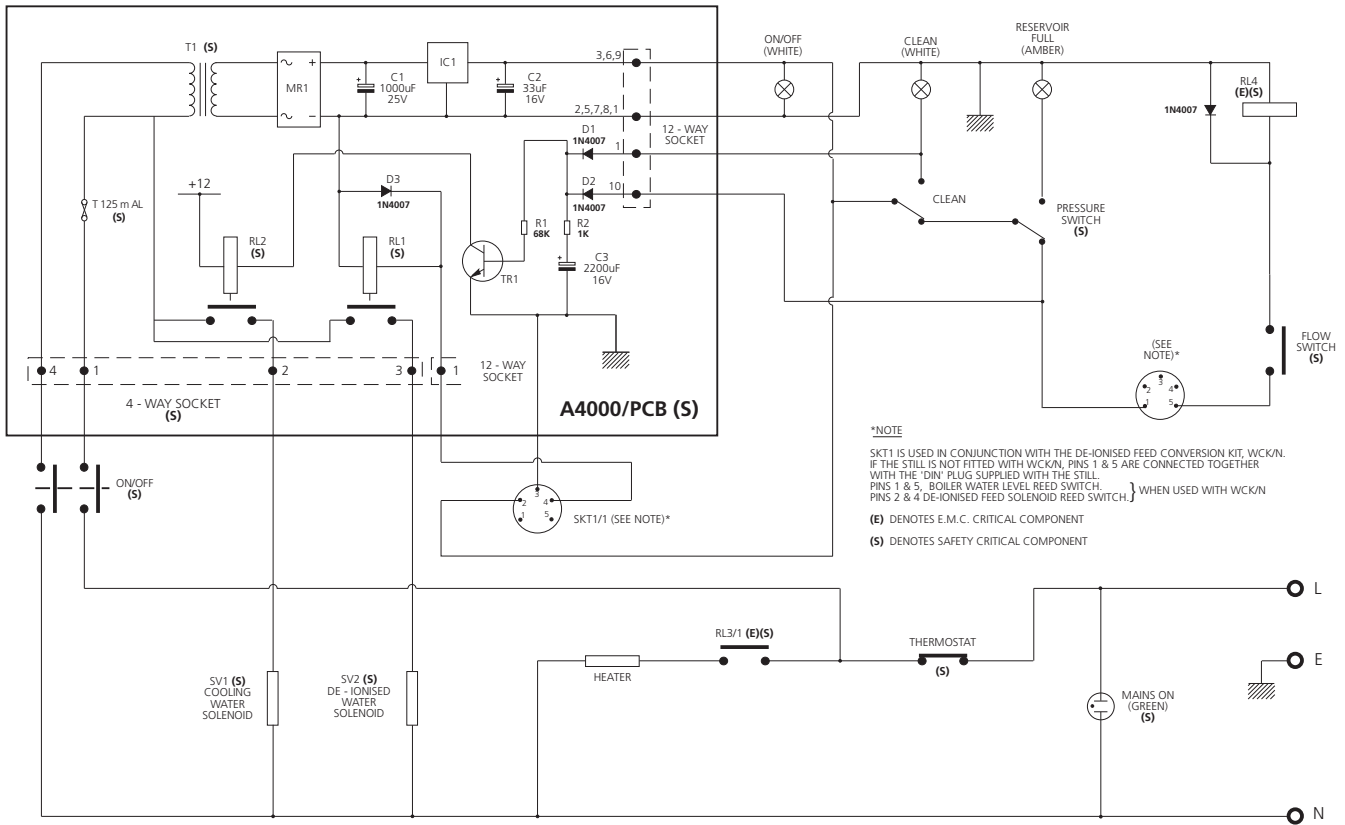

Wiring diagram for A4000

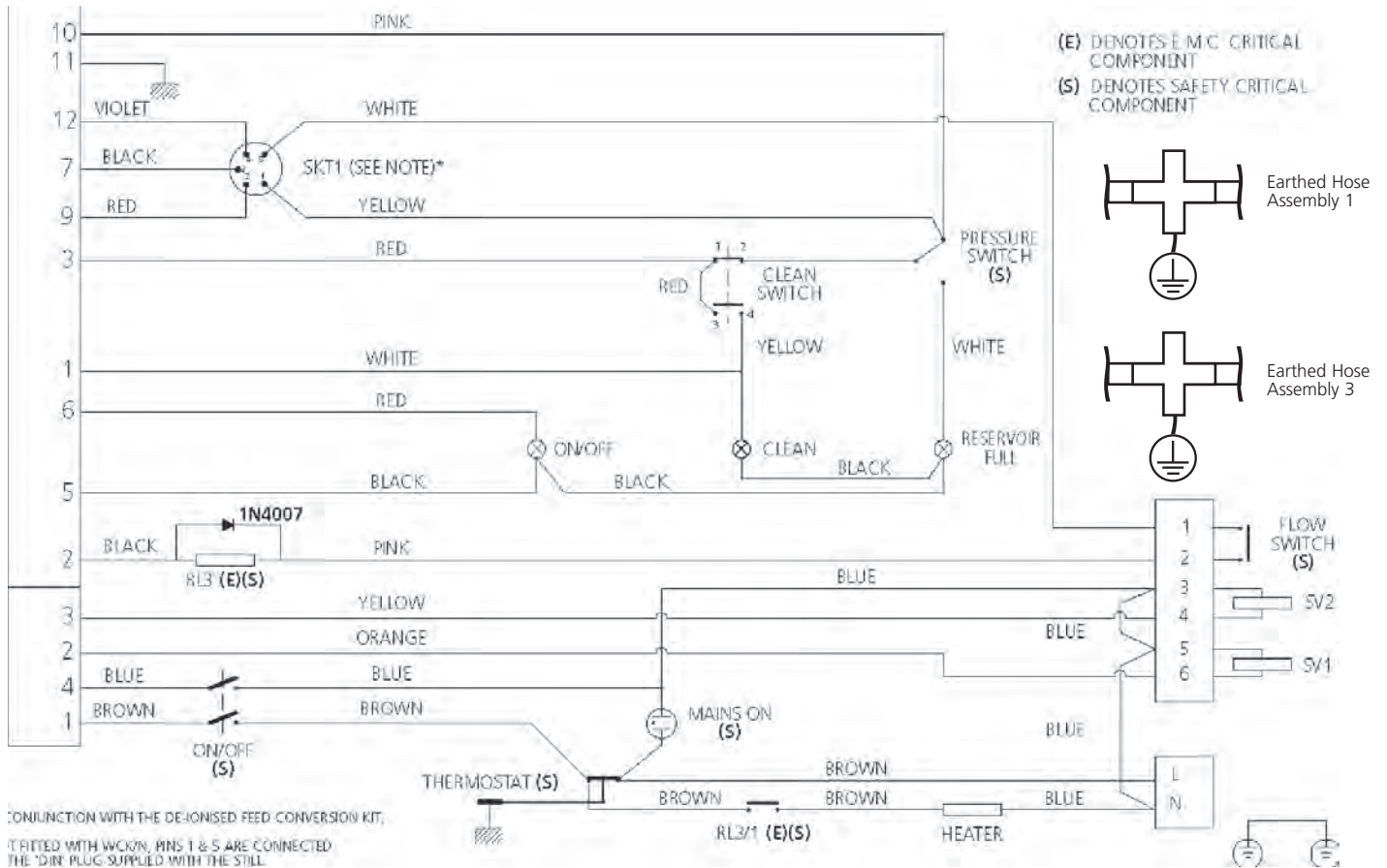

Circuit diagram for A8000

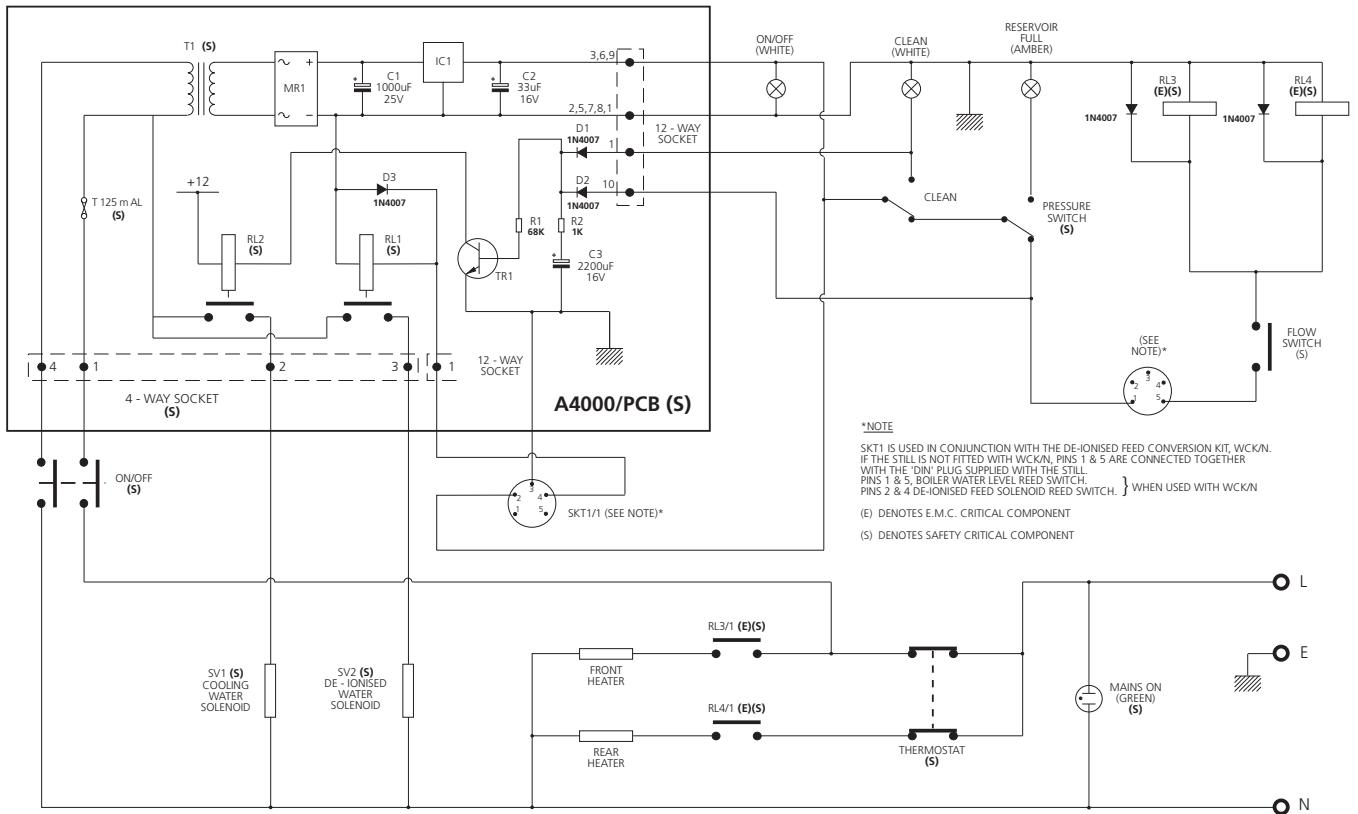

Wiring diagram for A8000

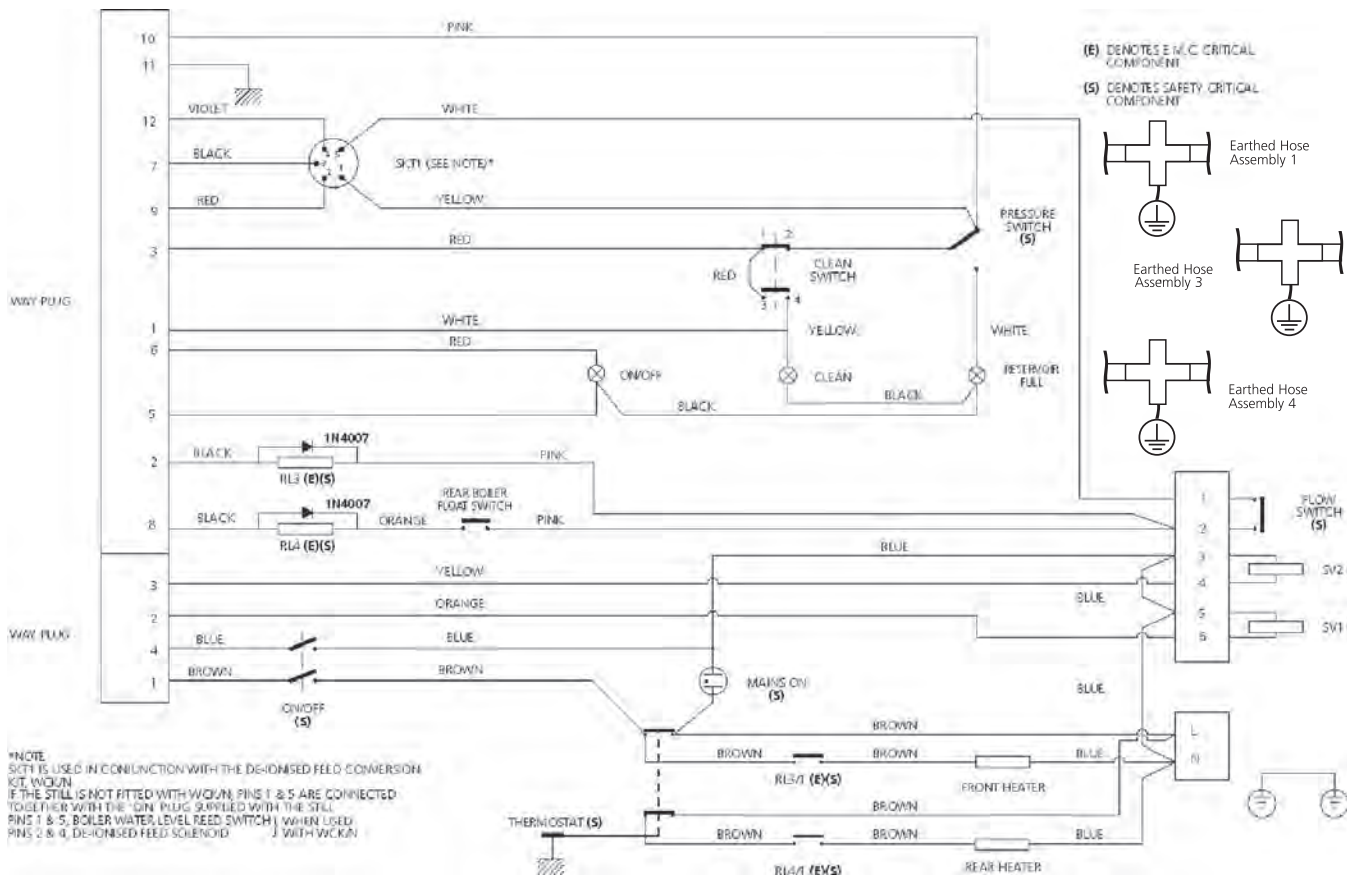

Circuit diagram for A4000D

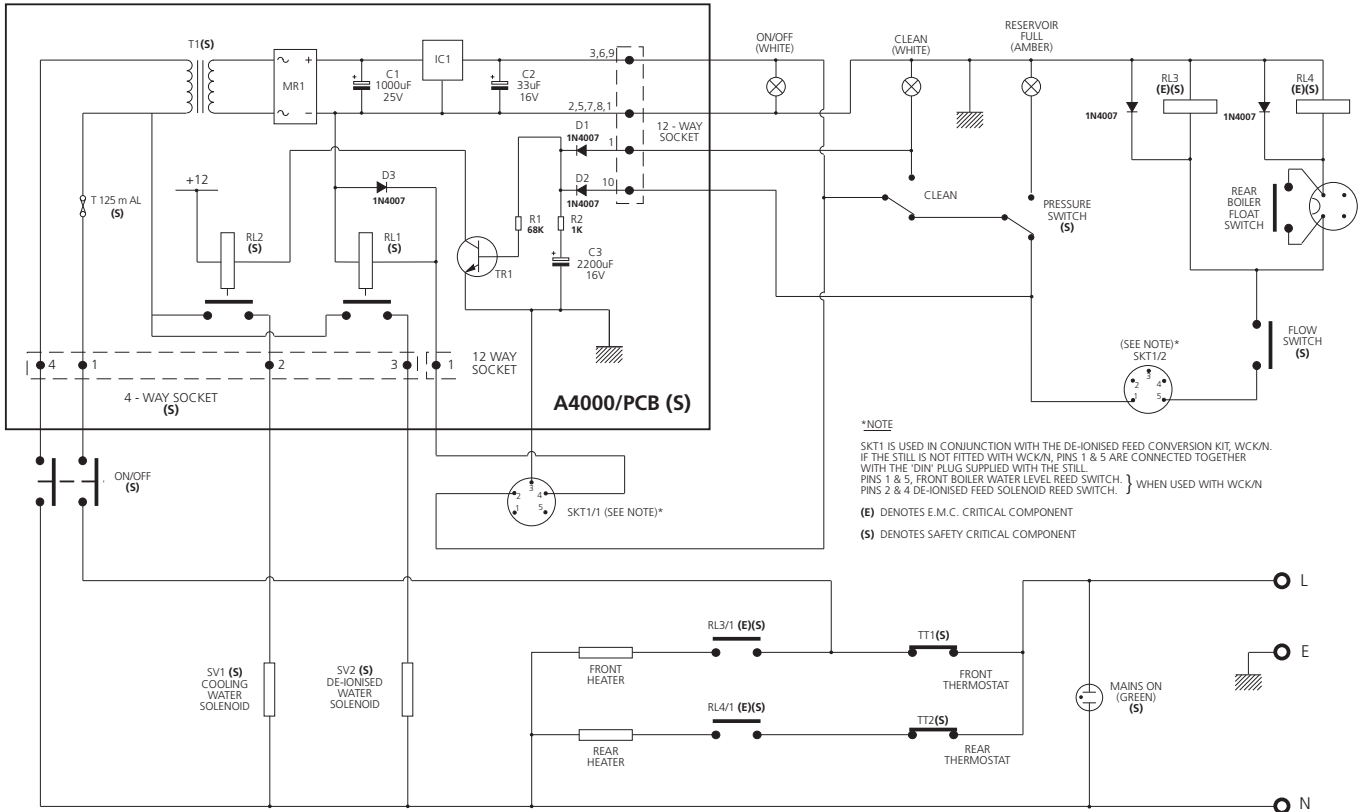

Wiring diagram for A4000D

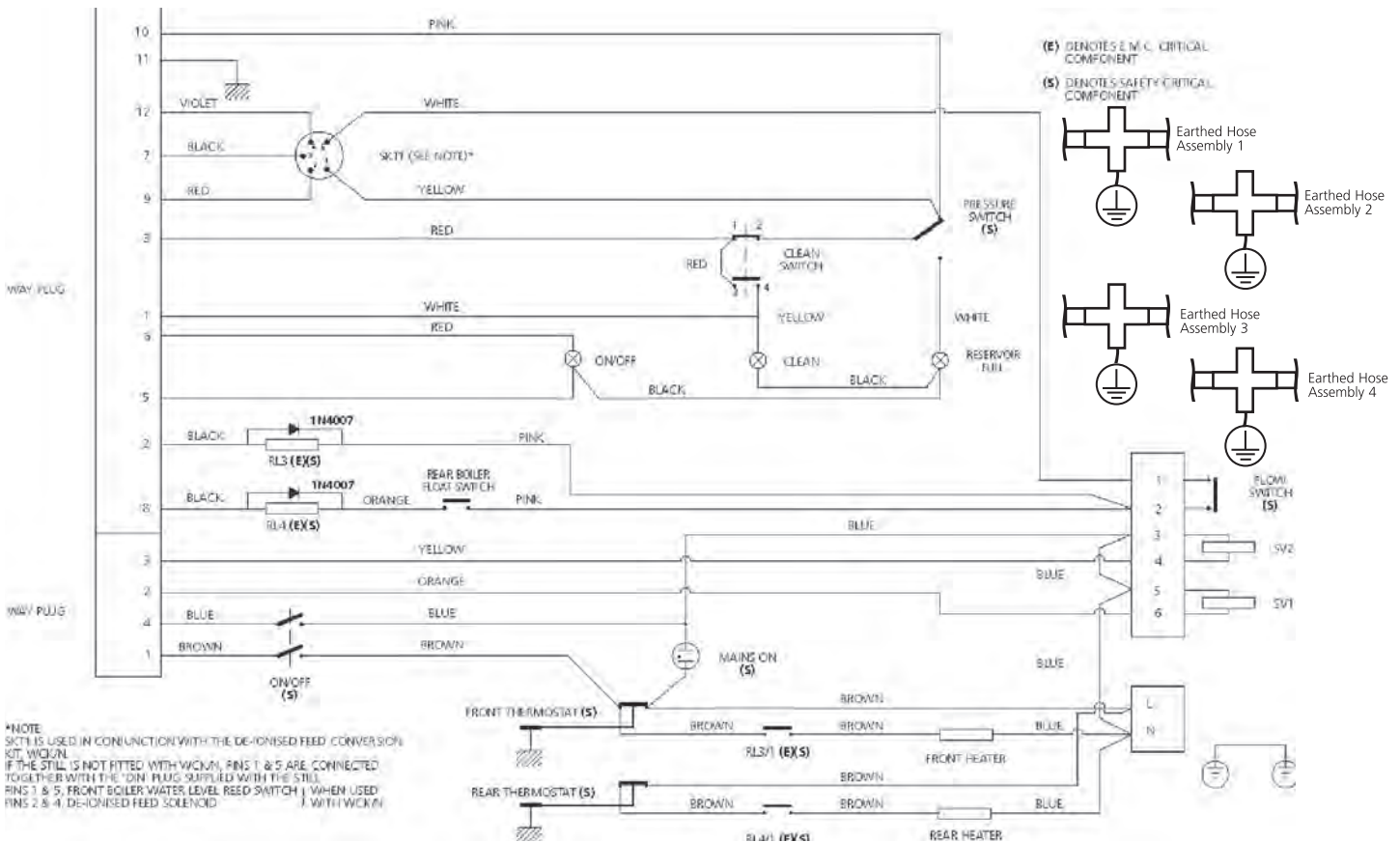



This product meets the applicable EC harmonized standards for radio frequency interference and may be expected not to interfere with, or be affected by, other equipment with similar qualifications. We cannot be sure that other equipment used in its vicinity will meet these standards

and so we cannot guarantee that interference will not occur in practice. Where there is a possibility that injury, damage or loss might occur if equipment malfunctions due to radio frequency interference, or for general advice before use, contact the Technical Department of Bibby Scientific Ltd.

Declaration of Conformity

Aquatron Water Stills, Model A4000, A8000 & A4000D

These products comply with the requirements of the EU Directives listed below:

2004/108/EC **EMC Directive.**
2006/95/EC **Low voltage Directive (LVD)**

Compliance with the requirements of these Directives is claimed by meeting the following standards:

EN 61326-1:2006 (Electrical Equipment for Measurement, Control and Laboratory use).
EN 61010-1: 2001
(Safety Requirements Electrical Equipment for Measurement, Control and Laboratory use)
EN 61010-2-010: 2003 (Particular Requirements for Laboratory Equipment for Heating of Materials).

Compliance Certificates and Full Reports.
Ref: RETS0287/9 and RETS0287/10

The above certificates and reports, from a independent test house, are available upon request.

CE mark affixed '01.

Signed:  (Mr S. Marriott)

Date: 14/4/11

Authority: Technical Director
Bibby Scientific Ltd

Bibby Scientific Bibby Scientific Ltd - Stone - Staffs - ST15 0SA - UK
Tel: +44 (0) 1785 812121 - Fax +44 (0) 1785 813748



Bibby Scientific Ltd

Beacon Road Stone
Staffordshire ST15 0SA
United Kingdom
Tel: +44 (0)1785 812121
Fax: +44 (0)1785 813748
e-mail: info@bibby-scientific.com
www.bibby-scientific.com

Bibby Scientific France SAS

ZI du Rocher Vert - BP 79
77793 Nemours Cedex
France
Tel: +33 1 64 45 13 13
Fax: +33 1 64 45 13 00
e-mail: bsf@bibby-scientific.fr
www.bibby-scientific.com

Bibby Scientific US Ltd

3 Terri Lane Suite 10
Burlington NJ 08016
USA
Tel: 800-225-9243
Fax: 609-589-2571
www.bibby-scientific.com

Bibby Scientific Italia Srl

Via Alcide de Gasperi 56
20077 Riozzo di Cerro al Lambro
Milano Italia
Tel: +39 (0)2 98230679
Fax: +39 (0)2 98230211
e-mail: marketing@bibby-scientific.it
www.bibby-scientific.it

Bibby Scientific (Singapore) Ltd

Prudential Tower, Level 26
30 Cecil Street
Singapore 049712
Tel: + 65 6631 2976
Fax: +44 (0) 1785 810405
e-mail : info@bibby-scientific.com
www.bibby-scientific.com