

# RV OIL SEALED ROTARY VANE PUMPS



# PERFORMANCE YOU CAN RELY ON

The RV series is the ultimate range of small oil sealed rotary vane pumps

The result of more than 75 years' experience and a clean sheet design programme, these rugged vacuum pumps offer an excellent ultimate vacuum with good pumping speeds as well as superior vapour handling capabilities and quiet operation.

High vapour handling

**Quicker process**

Superior particulate handling

**High reliability**

Fast acting, automatic inlet valve for best in class anti-suck back protection

**Safe process and systems**

Mode selector and two position gas ballast

**Configured to meet your vacuum needs**

Designed for easy maintenance

**No unplanned downtime**

Quiet running

**Better work environment**

## Applications

You can be assured Edwards has the application expertise and the RV pump or integrated system solution to meet your needs.

### Mass spectrometry

- GCMS, LCMS, ICPMS, MALDI, RGA, surface science, leak detectors

### Electron microscopy

- TEM, SEM, sample coatiers

### Sample preparation

- Gel dryers, glove boxes, rotary evaporators, centrifuges

### Research and development

- Chamber evacuation, coating systems, turbomolecular pump backing

### High energy physics

- Beam lines, accelerators, mobile pump carts, turbomolecular pump backing, laser evacuation

### Industrial

- Glove boxes, coating systems, freeze drying, gas bottle filling/emptying, refrigeration system manufacture, degassing/curing (oil, epoxy resin)

### Chemical

- Gel dryers, glove boxes, rotary evaporators, centrifuges, distillation/extraction/filtration

# Features and benefits

## Gas ballast

Two position gas ballast allows either 60 g/hr or a class leading 220 g/hr (290 g/hr on RV12) of water vapour to be handled. This can be combined with an oil return accessory and an oil mist filter to enable continuous pumping with no loss of lubrication. Gas ballast can be automated by fitting the optional solenoid operated gas ballast valve.

## Motor

Universal motor to cover the widest possible voltage and frequency range from a single motor. The single phase motor has an external switch to change from high to low voltage range. A universal 3 phase motor is also available on all models and for special applications, pumps with flameproof ATEX approved motors can be offered.

## Inlet

Best in class anti-suckback protection

- Smooth controlled opening by oil pressure to eliminate pressure surges
- Rapid closing within 0.4 seconds of pump stopping

All Edwards RV pumps are supplied with an inlet seal and integrated inlet mesh filter.

## Designed for easy maintenance

- One size hex-head wrench to dismantle all parts
- All parts self-aligning so no jigs or special assemblies required
- Polymer blades with no springs or pins for easier assembly and greater reliability
- Shaft seals can be replaced from the motor side without dismantling the pump mechanism
- No O-rings between the slices for easier assembly

## Oil

Edwards RV pumps are supplied with an initial charge of Ultragrade 19 oil. This premium quality oil has been specifically formulated with a unique package of additives to give the best vacuum performance of any mineral oil. As such it combines an extremely tightly controlled vapour pressure with a high resistance to oxidation for a long life. For oxygen rich applications PFPE prepared pumps are also available. Fomblin® must be purchased separately for PFPE prepared pumps.

## Mode switch

The unique mode selector switch means that one pump fits all, so you only need one model for both high throughput and high vacuum applications.

In high throughput mode the selector switch increases the oil flow to the high vacuum stage allowing the pump to operate continuously with high inlet pressures without any wear or loss of lubrication.



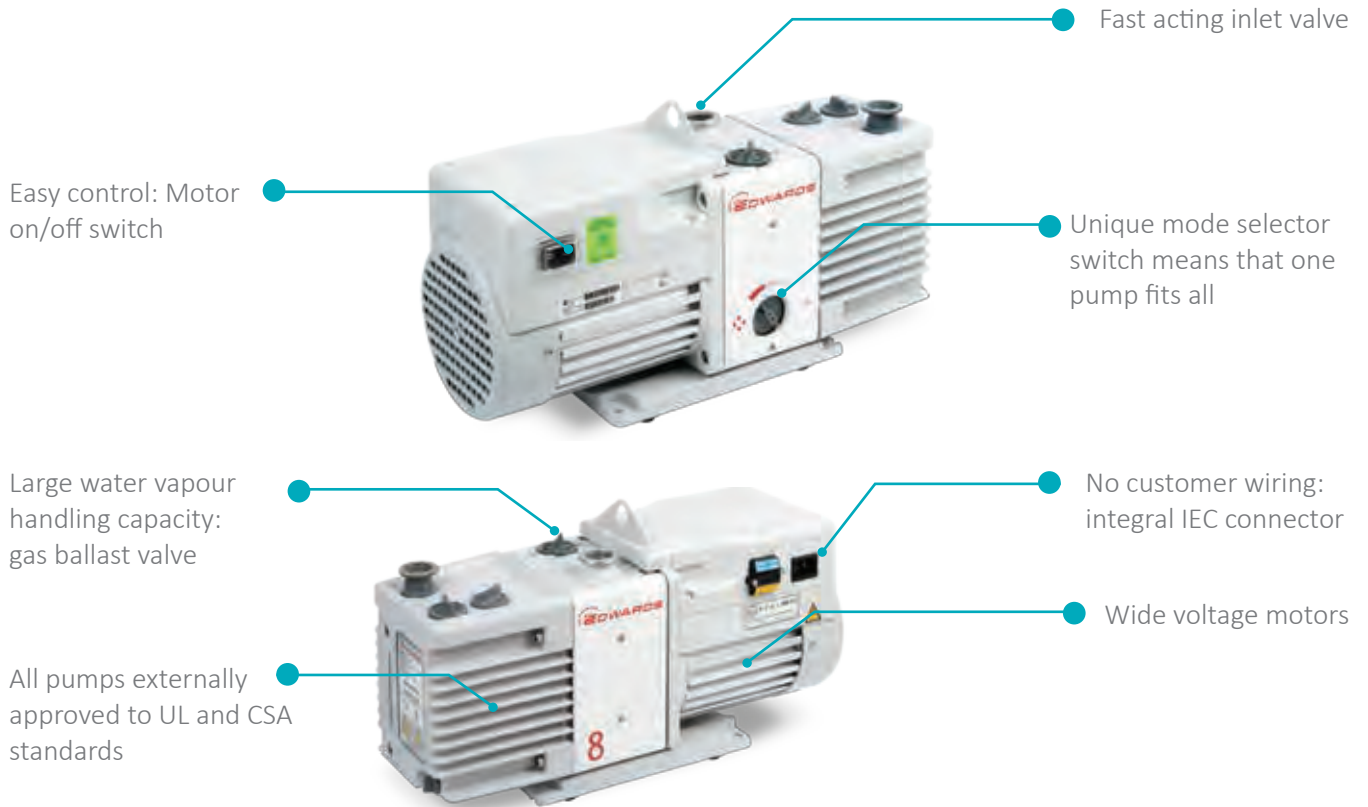

## Dimensions

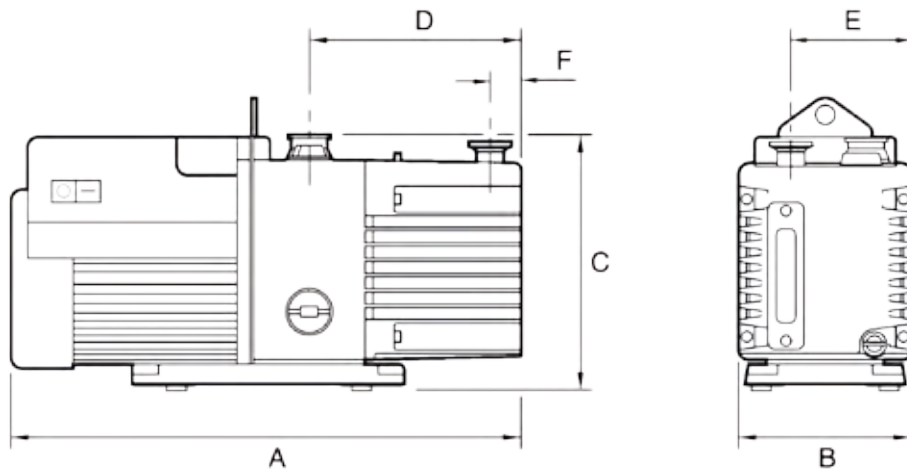

	A	B	C	D	E	F
<b>RV3</b>	430 (16.93)	158 (6.22)	225 (8.86)	156 (6.41)	111 (4.37)	29 (1.14)
<b>RV5</b>	430 (16.93)	158 (6.22)	225 (8.86)	156 (6.41)	111 (4.37)	29 (1.14)
<b>RV8</b>	470 (18.50)	158 (6.22)	225 (8.86)	196 (7.72)	111 (4.37)	35 (1.38)
<b>RV12</b>	490 (19.29)	158 (6.22)	225 (8.86)	216 (8.50)	111 (4.37)	35 (1.38)

Note: Single phase pump diagram shown, 3 phase pumps look different but share the same dimensions.  
Dimensions shown in mm(inch).

# Technical data

	Hz	Units	RV3	RV5	RV8	RV12
Peak pumping speed	60	cfm	2.3	3.6	5.9	8.4
	50	m <sup>3</sup> /h	3.3	5.1	8.5	12
Ultimate pressure (Total)	60	Torr	1.5 x 10 <sup>-3</sup> (1.5 x 10 <sup>-2</sup> with Fomblin®)			
	50	mbar	2.0 x 10 <sup>-3</sup> (2.0 x 10 <sup>-2</sup> with Fomblin®)			
Ultimate pressure GB I (Total)	50/60	Torr	2.3 x 10 <sup>-2</sup>			
		mbar	3.0 x 10 <sup>-2</sup>			
Ultimate pressure GB II (Total)	50/60	Torr	9.1 x 10 <sup>-2</sup>	9.1 x 10 <sup>-2</sup>	4.6 x 10 <sup>-2</sup>	9.1 x 10 <sup>-2</sup>
		mbar	1.2 x 10 <sup>-1</sup>	1.2 x 10 <sup>-1</sup>	6.0 x 10 <sup>-2</sup>	1.2 x 10 <sup>-1</sup>
High throughput mode	50/60	Torr	2.3 x 10 <sup>-2</sup>			
		mbar	3.0 x 10 <sup>-2</sup>			
Water vapour tolerance		Torr	60	38	38	24
		mbar	80	50	60	32
Water vapour capacity - GB I		g/h	60	60	60	60
Water vapour capacity - GB II		g/h	220	220	220	290
<b>Motor data</b>						
Motor rating 1 phase (nominal)	60	W	550			
	50	W	450			
Motor rating 3 phase	60	W	300	300	550	550
	50	W	250	250	450	450
Nominal rotation speed	60	rpm	1800			
	50	rpm	1500			
<b>Physical data</b>						
Weight		lb	55	55	61.6	63.8
		kg	25	25	28	29
Oil capacity		litres	0.7	0.7	0.75	1
Oil type (Ultragrade)			19			
Inlet flange			NW25			
Exhaust flange			NW25			
Noise level	50 Hz	dB(A)	48			
Noise level (with Acoustic Enclosure)*	50 Hz	dB(A)	41			
Operating temperature range		°C	12 to 40			

\* approximate noise reduction of 7 dB(A)

# Ordering information

	Product description	Order No.	Order No.
		Ultragrade Oil	PFPE prepared*
RV3	115/230V, 50/60Hz set to 230V	A65201903	A65209903
	100/200V, 50/60Hz set to 200V	A65201904	A65209904
	200-220/380-415V, 50Hz 200-230/460V, 60Hz, 3 phase	A65201905	A65209905
	115/230V, 50/60Hz set to 115V	A65201906	A65209906
RV5	115/230V, 50/60Hz set to 230V	A65301903	A65309903
	100/200V, 50/60Hz set to 200V	A65301904	A65309904
	200-220/380-415V, 50Hz 200-230/460V, 60Hz, 3 phase	A65301905	A65309905
	115/230V, 50/60Hz set to 115V	A65301906	A65309906
RV8	115/230V, 50/60Hz set to 230V	A65401903	A65409903
	100/200V, 50/60Hz set to 200V	A65401904	A65409904
	200-220/380-415V, 50Hz 200-230/460V, 60Hz, 3 phase	A65401905	A65409905
	115/230V, 50/60Hz set to 115V	A65401906	A65409906
RV12	115/230V, 50/60Hz set to 230V	A65501903	A65509903
	100/200V, 50/60Hz set to 200V	A65501904	A65509904
	200-220/380-415V, 50Hz 200-230/460V, 60Hz, 3 phase	A65501905	A65509905
	115/230V, 50/60Hz set to 115V	A65501906	A65509906

\*PFPE fluid not included

	Product description	Order No.
Cord sets	UK, three pin plug	A50505000
	North European plug	A50506000
	North American plug	A50507000
	No plug	A50508000
Oil	Ultragrade 19, 1 litre bottle	H11025015
	Fomblin® YVAC 06/6 1kg (532 ml)	H11301019
	Ultragrade 19 oil 4 litre	H11025013
Inlet accessories	Foreline trap - FL20K	A13305000
Outlet accessories	Oil mist filter - EMF10	A46226000
	Oil mist filter - EMF20	A46229000
Oil return kits	Clean application (no gas ballast)	A50420000
	Adjustable gas ballast	A50523000
Vibration isolators		A24801404
Spares kits	Clean and overhaul kit	A65201131
Acoustic enclosure	Low volts 110-120V	NRD317000
Acoustic enclosure	High volts 200-240V	NRD318000

Pumps fitted with ATEX approved motors are available, contact Edwards for details  
Pumps are supplied with initial charge of Ultragrade oil

